

PLASKOLITE

**TUFFAK® POLYCARBONATE
SHEET**

FABRICATION GUIDE

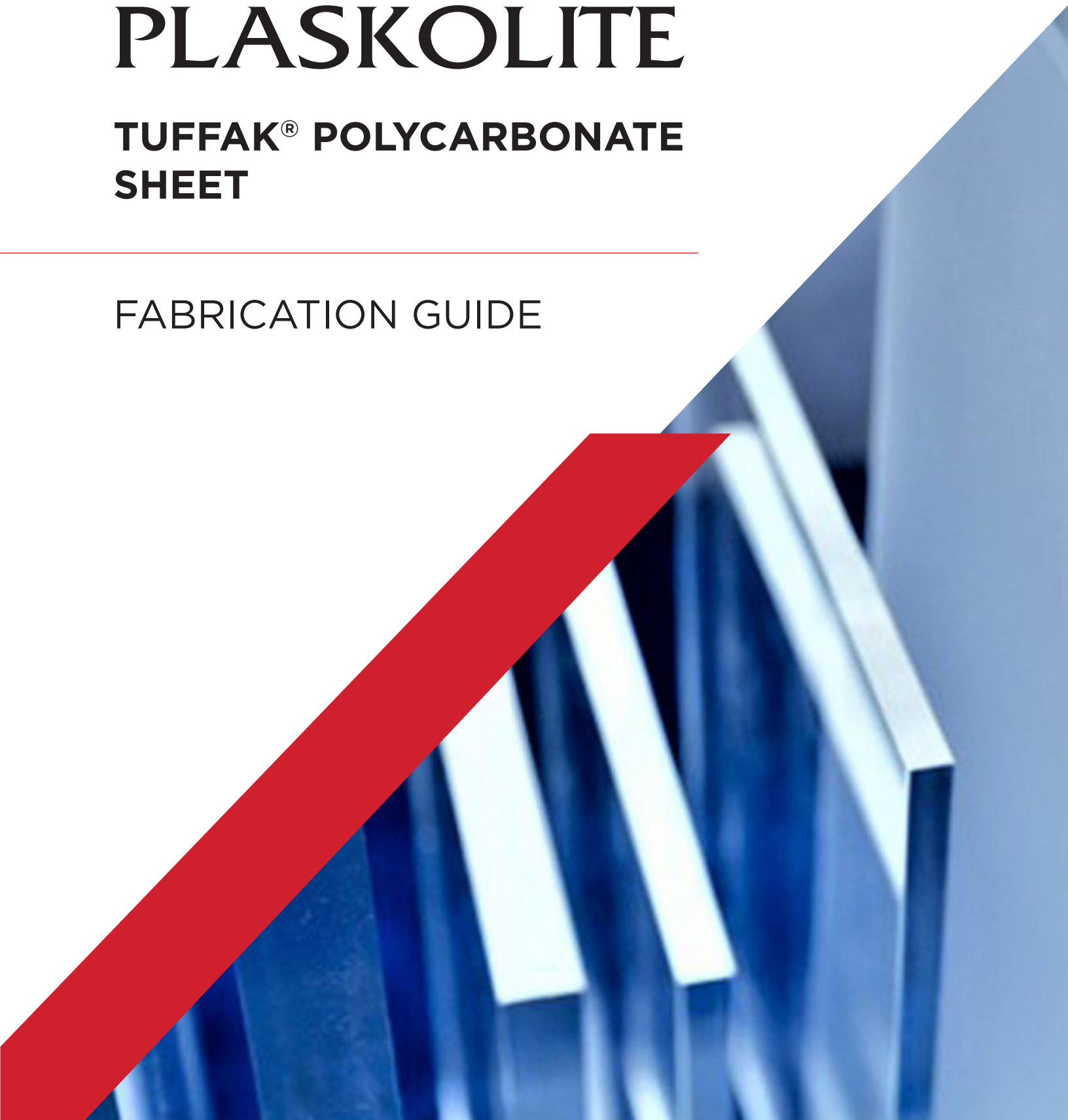

TABLE OF CONTENTS

Introduction	4
Quality / Attributes	5
Typical Properties	6-7
TUFFAK Product Selection Guide	8-10
Chemical / Environmental Resistance	11-17
Cleaning / Storage	18-19
Fabrication / Machining	20-26
Fabrication / Laminate & Heavy Gauge Sheet ..	27-30
Thermoforming	31-38
Troubleshooting Guide	39-47
Brake Bending, Cold Forming, Annealing	48-49
Bonding Applications	50-53
Mechanical Fastening	54-57
Finishing	58-60
Glazing Guidelines	61-67



Contact Technical Service Group with additional questions:

800.628.5084

plaskolite@plaskolite.com

INTRODUCTION

TUFFAK is the tradename for extruded solid polycarbonate sheet made by Plaskolite. Polycarbonate was first produced in the late 1950's and initially was used for electrical applications. Its unique combination of transparency, high impact and high heat resistance made it the preferred choice for many applications.

Polycarbonate merges its unique combination of beneficial properties with UV stabilizers and enhancements to offer protection for UV, sunlight and environmental, exposure for an extended period of time. It also has excellent electrical properties and is flame self-extinguishing. Polycarbonate can be modified by different additives to perform specific applications such as; light diffusion, IR blocking, UL94 flame resistance, and laser-blocking resistance. The sheets can be coated with an abrasion resistant polymer for increased scratch resistance with a hard coat or formable coating, polycarbonate and capped with a robust UV blocking coating providing extended outdoor life for up to 10 years. Polycarbonate meets challenges in many applications under NHTSA-DOT, FAA, UL Electrical Resistance, FRA, FDA, forced/entry containment, ballistic applications, architectural glazing, sign industry, safety guarding, marine glazing, lighting industry, and interior fire protection.

With excellent transparency, safety and ease of fabrication, TUFFAK extruded solid polycarbonate sheets provides long-life in a wide range of applications. TUFFAK is available in sheets and reels and a range of thicknesses, colors, textures, and diffusers.

TUFFAK polycarbonate optical grades sheet are produced in clean room environment using computerized state-of-the-art video technology in order to detect any imperfections. A skilled team works to improve materials and processes, and provide technical support to customers.

QUALITY AND ATTRIBUTES OF TUFFAK

- High clarity and light transmission
- Low haze
- Polished surface
- Matte, Prismatic, Haircell, and Pebble textures available
- Outstanding impact strength - virtually unbreakable
- Excellent heat resistance - continuous service temperature up to 100°C/212°F
- Lightweight, almost half the weight of glass
- UV protective layer, one or two sides, excellent weathering, and aging resistance.
- Ten year limited warranty against breakage and UV discoloration
- Excellent color stability.
- A wide range of translucent tints and opaque colors available
- Excellent dimensional stability
- Easily machined and thermoformed by standard techniques
- Cold curving capability to 100x its radius
- Can be glued and solvent bonded
- Good chemical resistance to a wide range of substances
- Sheets are protected with films which are fully recyclable
- Does not contain toxic materials or heavy metals, which may cause environmental damage or health risks
- REACH, RoHS and other regulatory declarations are available on Plaskolite.com
- Flame resistant, self-extinguishing. Flame retardant UL94 V-0 grades (FI, LF) available
- TUFFAK FD is produced under FDA regulation 21 CFR § 177.1580 and uses NSF listed resin. TUFFAK FD is also a medical grade resin meeting ISO 10993 and USP Class VI

TECH TIP:

Polycarbonate sheets and their polyethylene protective masking layers are fully recyclable. Polycarbonate recycle number 7, PE film recycle number 4.



TUFFAK SHEET TYPICAL PROPERTIES*

Property	Test Method	Units	Values
PHYSICAL			
Specific Gravity	ASTM D 792	-	1.2
Refractive Index	ASTM D 542	-	1.586
Light Transmission, Clear @ 0.118"	ASTM D 1003	%	86
Light Transmission, I30 Gray @ 0.118"	ASTM D 1003	%	50
Light Transmission, K09 Bronze @ 0.118"	ASTM D 1003	%	50
Light Transmission, I35 Dark Gray @ 0.118"	ASTM D 1003	%	18
Water Absorption, 24 hours	ASTM D 570	%	0.15
Poisson's Ratio	ASTM E 132	-	0.38
MECHANICAL			
Tensile Strength, Ultimate	ASTM D 638	psi	9,500
Tensile Strength, Yield	ASTM D 638	psi	9,000
Tensile Modulus	ASTM D 638	psi	340,000
Elongation	ASTM D 638	%	110
Flexural Strength	ASTM D 790	psi	13,500
Flexural Modulus	ASTM D 790	psi	345,000
Compressive Strength	ASTM D 695	psi	12,500
Compressive Modulus	ASTM D 695	psi	345,000
Izod Impact Strength, Notched @ 0.125"	ASTM D 256	ft·lbs/in	18
Izod Impact Strength, Unnotched @ 0.125"	ASTM D 256	ft·lbs/in	60 (no break)
Instrumented Impact @ 0.125"	ASTM D 3763	ft·lbs	47
Shear Strength, Ultimate	ASTM D 732	psi	10,000
Shear Strength, Yield	ASTM D 732	psi	6,000
Shear Modulus	ASTM D 732	psi	114,000
Rockwell Hardness	ASTM D 785	-	M70 / R118
THERMAL			
Coefficient of Thermal Expansion	ASTM D 696	in/in/°F	3.75 x 10 ⁻⁵
Coefficient of Thermal Conductivity	ASTM C 177	BTU·in/hr·ft ² ·°F	1.35
Heat Deflection Temperature @ 264 psi	ASTM D 648	°F	270
Heat Deflection Temperature @ 66 psi	ASTM D 648	°F	280
Brittleness Temperature from ductile to brittle	ASTM D 746	°F	-40 - -200
Shading Coefficient, clear @ 0.236"	NFRC 100-2010	-	0.97
Shading Coefficient, Gray or Bronze @ 0.236"	NFRC 100-2010	-	0.77
U factor @ 0.236" (summer, winter)	NFRC 100-2010	BTU/hr·ft ² ·°F	0.85, 0.92
U factor @ 0.375" (summer, winter)	NFRC 100-2010	BTU/hr·ft ² ·°F	0.78, 0.85
ELECTRICAL			
Dielectric Constant @ 10 Hz	ASTM D 150	-	2.96
Dielectric Constant @ 60 Hz	ASTM D 150	-	3.17
Volume Resistivity	ASTM D 257	Ohm·cm	8.2 x 10 ¹⁶
Dissipation Factor @ 60 Hz	ASTM D 150	-	0.0009
Arc Resistance			
Stainless Steel Strip electrode	ASTM D 495	Seconds	10
Tungsten Electrodes	ASTM D 495	Seconds	120
Dielectric Strength, in air @ 0.125"	ASTM D 149	V/mil	380

*Typical properties are not intended for specification purposes.

TUFFAK SHEET TYPICAL METRIC PROPERTIES*

Property	Test Method	Units	Values
PHYSICAL			
Density	ISO 1183	g/m ³	1.2
Refractive Index	ISO 489	-	1.586
Light Transmission, Clear @ 3mm	ASTM D 1003	%	86
Light Transmission, I30 Gray @ 3mm	ASTM D 1003	%	50
Light Transmission, K09 Bronze @ 3mm	ASTM D 1003	%	50
Light Transmission, I35 Dark Gray @ 3mm	ASTM D 1003	%	18
Water Absorption, 24 hours	ISO 62 (1)	%	0.15
Haze @ 3mm	ASTM D 1003	%	<1
MECHANICAL			
Tensile Strength, Ultimate	ASTM D 638	MPa	66
Tensile Strength, Yield	ISO 527-2	MPa	62
Tensile Modulus	ISO 527-2	MPa	2340
Elongation at Break	ISO 527-2	%	110
Flexural Strength	ISO 178	MPa	93
Flexural Modulus	OSO 178	MPa	2380
Compressive Strength	ASTM D 695	MPa	86
Compressive Modulus	ASTM D 695	MPa	2380
Izod Impact Strength, Notched	ISO 180/1A	kJ/m ²	>65
Izod Impact Strength, Unnotched	ISO 179/1eU	kJ/m ²	No break
Instrumented Impact @ 3.1mm	ASTM D 3763	J	64
Shear Strength, Ultimate	ASTM D 732	MPa	69
Shear Strength, Yield	ASTM D 732	MPa	41
Shear Modulus	ASTM D 732	MPa	786
Rockwell Hardness	ASTM D 785	-	M70 / R118
THERMAL			
Coefficient of Linear Thermal Expansion	ISO 11359-2	um/m-°C	68
Thermal Conductivity	ASTM C 177	Cal cm/sec.cm ² .°C	1.35
Heat Deflection Temperature @ 1.86 MPa	ASTM D 648	°C	132
Vicat Softening Temp (50N)	ASTM D 648	°C	144
Brittleness Temperature	ASTM D 746	°C	-129
Shading Coefficient, clear @ 6mm	NFRC 100-2010	-	0.97
Shading Coefficient, Gray or Bronze @ 6mm	NFRC 100-2010	-	0.77
U factor @ 6mm (summer, winter)	NFRC 100-2010	W/m ² .°C	4.83, 5.22
U factor @ 9.54mm (summer, winter)	NFRC 100-2010	W/m ² .°C	4.43, 4.83
ELECTRICAL			
Dielectric Constant @ 50 Hz	DIN 53483	-	3.0
Surface Resistivity	IEC 60093	Ohm	>10 ¹⁴
Volume Resistivity	IEC 60093	Ohm-cm	>10 ¹⁵
Dissipation Factor @ 100 Hz & 1MHz	DIN 53483	-	0.0006/0.0009
Arc Resistance			
Stainless Steel Strip electrode	ASTM D 495	Seconds	10
Tungsten Electrodes	ASTM D 495	Seconds	120
Dielectric Strength, in air @ 3mm	ASTM D 149	V/mil	15000

*Typical properties are not intended for specification purposes.

TUFFAK PRODUCT SELECTION GUIDE

TUFFAK Grade	Key Product Features	Typical Applications
GP/GP-V	High impact; clarity; and temperature resistant, GP-V is flame retardant	Industrial glazing, machine guards, structural parts, thermoformed and fabricated components
GP Patterns	Pebble, matte and prismatic surface finishes	Industrial glazing, privacy glazing, signs, displays, and lighting covers
OP	Optical Quality	Face shields, laminates
FI	UL 94 V-0, 5VA; FAA rated; not UV stabilized	Electrical devices, equipment housings, switchgear covers, and interior aircraft components
LF	UL 94 V-0; FAA rated has UV stabilizer	Electrical devices, equipment housings, switchgear covers, light fixtures, aerospace components
FD	FDA compliant for food contact	Machine guards, bulk food bins, candy molds, sneeze guards, hospital trays, bassinets, incubators, and medical device storage containers
SL/SL-V	Enhanced outdoor weathering performance, SL-V is flame retardant	Flat and formed sign faces and channel letters
SL Matte	Enhanced outdoor weathering performance with matte texture	Flat and formed sign faces, channel letters and digital displays
LD	LED light diffusion; enhanced outdoor weathering performance	Flat and formed sign faces and channel letters using LEDs
NR	Non-reflective; UV resistant; proprietary matte surface; impact strength	Display and screen protection, signage, lenses, and menu boards
NR-C	Non-reflective; UV resistant; one side hard-coated; textured surface	Display and screen protection, fuel dispensing systems, signage, lenses, and menu boards with improved chemical resistance
UV	High optical quality enhanced outdoor weathering performance and can be cold formed on site	Covered pedestrian walkways, entryway canopies, awnings, skylights, barrel vaults, glazed archways, and sloped, vertical, and curved glazing
SK	Designed as inner light of a dual domed skylight	Awning, skylights, entryway canopies, barrel vaults, sloped, vertical and curved glazing
SK1	Smooth and prismatic optimized to diffuse and distribute light with high light transmission; UV resistant	Awning, skylights, entryway canopies, barrel vaults, sloped, vertical and curved glazing
AR	Long lasting abrasion and chemical resistance, and outdoor weathering performance	Replacement glazing, industrial guarding, safety components
15	Long lasting abrasion and chemical resistance, and outdoor weathering performance; Fifteen (15) year limited product warranty	Architectural glazing for residential, retail, transportation centers, psychiatric facilities
FC	Cold formable and drape formable; meets ANSI Z26.1 AS-6	Motorcycle and recreational vehicle windscreens, face shields, and formed applications
CG375, CG500, CG750	Meets ASTM F 1915; ASTM F 1233; H.P. White TP 0500	Jails, prisons, detention and psychiatric containment glazing

TUFFAK Grade	Key Product Features	Typical Applications
BR750	Meets UL 752	Ballistic resistant glazing for government, institutional and commercial installations
BR1000	Meets UL 752 Level 2; ASTM F 1233; ASTM F 1915; H.P. White TP 0500	Ballistic resistant glazing for government, institutional, banks and commercial installations
BR1250	Meets UL 752 Level 3; NIJ Level II; ASTM F 1233; ASTM F 1915; H.P. White TP 0500	Ballistic resistant glazing for government, institutional, banks commercial installations
MS1250	Meets UL 752 Level 6	Ballistic resistant glazing for severe threat
Lumen XT	Superior LED and conventional light diffusion; wide range of diffusion levels	Interior LED and conventional lighting fixtures
Lumen XT-V	Meets UL 94 V-0, 5VA	Interior LED and conventional lighting fixtures
DX-NR	Specifically formulated for superior LED light diffusion with enhanced weathering performance	Exterior LED and conventional lighting fixtures
IR	Meets welding shades 3 and 5; complies with ANSI Z87.1, EN 169; CSA Z94.3	Face shields for flame welding and cutting, general IR protection, welding curtain
MG	0.750" - 2.0" (19.0 - 50.8mm) thick for machining, textured surface	Machined parts such as manifolds, insulators, diaphragms, electrical, semiconductor, military applications
WG	0.750" - 2.0" (19.0 - 50.8mm) thick, transparent	Sight windows for tanks/vessels, viewports, medical parts, military applications
AU	UV and abrasion resistant; ultra clear; high visible light transmission	Specialty laminates
UC	High light transmission; and high optical quality	Military aircraft canopies, specialty laminates
SQ	High optical quality	High optical quality with specifications tailored to end-use application
HV	UV and abrasion resistant; high optical quality thick gauge sheet; meets ANSI Z26.1 AS-4	Forestry equipment, agricultural and industrial vehicle glazing
TX	Extended UV and abrasion resistant glazing for windows; meets ANSI Z26.1 AS-4 and FMVSS 302	RV, construction, and commercial truck rear windows
BG	UV and abrasion resistant; optical performance meets ANSI Z26.1 AS-4 and FMVSS 302	Bus window glazing
TG	High optical performance with enhanced UV and abrasion resistance; meets FRA 49 CFR 233 & 49 CFR 238 for flammability, smoke, ballistics, and impact	Passenger rail car glazing
Marine 5	High optical clarity; low optical distortion; UV, abrasion, and chemical resistant	Marine flexible enclosures, tent and awning enclosures
VR	High optical quality; low optical distortion; high clarity	Marine flexible enclosures, tent and awning enclosures
AL	High optical quality; abrasion, chemical and UV resistant	Automotive laminates

TUFFAK Grade	Key Product Features	Typical Applications
CA/ CA-UV/ CA-AR	Optical grade meeting ICB Class A flammability; passes NFPA 286	Wall cladding, ceiling finishes, Exterior glazing and canopies and flat architectural glazing
WC	Effectively blocks 100% of harmful UV light, hazardous blue-light, a common cause of "welder arc-eye"; complies with AWS F2:3M:2011	Welding curtains, screens, booths, enclosures and walkways, tanning salons screens and other high UV and lighted areas visibleazing, privacy glazing, signs, displays, and lighting covers
LS	Available in IR, Visible and UV laser blocking tints; certified to ANSI Z136.7	Door and room windows, standing panels and screens, modular barriers and enclosures where reflective laser light blocking is required
DG	High optics, abrasion resistant for driver guard; conforms to FMVSS 205/ANSI Z26.1. AS4	Transportation approved glazing for use as protective bus driver surrounds
Mirror. Mirror AR	Mirror/ Mirror AR UL 94 V-0; FAA rated has UV stabilizer	High traffic and abusive environments, jails, detention centers, gyms, hospitals, amusement parks, casinos, toys



CHEMICAL / ENVIRONMENTAL RESISTANCE

CHEMICAL / ENVIRONMENTAL RESISTANCE

The chemical and environmental resistance of TUFFAK depends on the unique combination of factors and variables it encounters in its application.

Outlined below is an overview of its primary outside influencers, and common types of potential damage. A summary of laboratory tests designed to meet its practical requirements, as well as its resistance to a wide range of chemicals and substances, is also provided.

Your Plaskolite Representative, with the support of our Technical Service group, is available to work with you to evaluate your specific application.

Influencing parameters

TUFFAK properties are influenced by:

- » The composition of chemical ingredients
- » Temperature
- » Duration of exposure
- » The level of internal or applied stress and strain

Types of damage

TUFFAK can sustain several distinct types of damage, including swelling, dissolution, stress cracking, and molecular degradation. Circumstances under which these potential types of damage can occur are detailed below. Different chemicals may act simultaneously on TUFFAK sheet causing one or more types of damage.

Swelling or dissolution

When low-molecular, aromatic, halogenated and polar components migrate into the polycarbonate, the damage can range from a tacky surface, to swelling, to complete dissolution.

Stress cracking

Even in small quantities, a number of chemicals can penetrate the surface of TUFFAK. This may result in stress cracks that affect the formed or fabricated part's appearance or mechanical properties.

With transparent grades of TUFFAK, stress cracks are generally easy to detect. In opaque grades, it may be difficult to detect them. Stress cracks can act like a notch, leading to significant deterioration in several mechanical properties, particularly impact, flexural, and tensile performance. Laboratory tests such as impact or flexural strength can be used as indicators for mechanical property degradation.

Temperature and the duration of exposure are key influencers in the potential cracking of TUFFAK. As temperature rises, the time that elapses before damage occurs shortens. The exposure time required for initial damage ranges from a few seconds to more than 1000 hours due to the chemical involved, temperature, and stress level. For example, when formed or fabricated parts with pronounced stresses are immersed in aggressive solvents, stress cracks will occur in less than one minute.

It is possible for a component within a solid to migrate to polycarbonate through long-term contact and cause damage. One example is the contact between polycarbonate and plasticized PVC. Plasticizers within PVC, such as phthalates can trigger stress cracking and result in damage to the polycarbonate.

Molecular degradation

Many of TUFFAK properties are determined by the size of its molecules. If an incompatible chemical causes a reduction in molecular weight, mechanical property degradation can occur. The molecular weight has virtually no influence on electrical properties and only a slight influence on thermal properties.

Solutions with a high pH (bases) can act to lower the molecular weight of polycarbonate. Low pH (acids) solutions typically do not degrade the molecular weight. Ammonia and amines are aggressive toward polycarbonate.

Plaskolite laboratories have tested a series of chemicals and commercial products to determine their compatibility with polycarbonate. The results of TUFFAK resistance to substances are included in the following table (pages 13-16).

Laboratory tests supply information on the formulation tested. The composition of many commercial products can change over time.

Oxidative damage

TUFFAK is relatively stable toward oxidizing agents such as oxygen, nitric acid, and hydrogen peroxide.

Resistance

TUFFAK's resistance to chemicals, common industrial cleaners, pharmaceuticals, household and cosmetic substances, is dependent on the ingredients in the product, as well as the temperature and duration of exposure. The following section provides a general overview of resistance to these commonly used materials. If you require additional information, please contact your Plaskolite representative.

» Resistance to sealing compounds, adhesives, and plastics

TUFFAK's resistance to sealants, adhesives, and plastics is largely dependent on the presence of aggressive components, such as plasticizers (e.g., phthalates) or solvents, which can migrate into polycarbonate.

» Resistance to paints

Solvents in paints may cause stress cracking or swelling depending upon the solvent and the flash-off and drying conditions. It is possible to formulate paints with solvents that do not cause damage. In some applications, painting can increase the chemical resistance of the finished part.

Two component paints are resistant if the individual components do not cause damage to TUFFAK in the short period between the application and curing. The SDS can be used to identify the chemical composition of the paint.

» Resistance to cleaning and washing agents

TUFFAK is resistant to most household soaps but not those containing amines, ammonia, and sodium hydroxide.

» Resistance to disinfectants, drugs, and cosmetics

TUFFAK may be damaged by disinfectants, drugs, and cosmetics, which contain solvents or active ingredients that are incompatible with polycarbonate. For example, nail polish and nail polish remover will cause damage to the material.

If the product ingredients are known, it is possible to estimate the compatibility with TUFFAK. However, it is recommended to put the finished part through a practical test if no data is available. Refer to the compatibility table (pages 13-16) for resistance levels.

CHEMICAL / ENVIRONMENTAL RESISTANCE

Environmental Stress Cracking:

ESC is considered a leading cause of plastic part failure. ESC is a result of the combination of stress and chemical exposure. Under harsh chemical environment, stressed sheets will fail by cracking and crazing. The level of stress needed for ESC is lower than the normal failure mechanical stress of polycarbonate in a chemical-free environment. Stresses can be induced during forming and fabrication.

Testing to meet practical requirements

The compatibility information presented in this section should be used as a starting point for determining the integrity and durability of your application. Testing is essential if finished TUFFAK components are likely to encounter aggressive chemicals during use. The internal and applied stress in a formed or fabricated part, as well as duration of chemical exposure, can lead to very different results.

Compatibility assessment methods

The data shown in the compatibility table (pages 15-18) was generated using DIN 53449-3. This method uses test pieces of 3.1" x 0.39" x 0.16" (80 x 10 x 4 mm) TUFFAK sheet clamped to a curved fixture. The fixture applies a graduated strain ranging from 0 to 2%.

Assessment criteria

The information in the compatibility tables are based on exposure to chemicals at 73°F (23°C) and a range from 0-2% strain. Components that lead to damage with a strain of ≤ 1.0 % are classified as incompatible.

The results shown in the following tables are based on a one-time test. Change in the composition by the producers of these substances can change the results.

Please contact your Plaskolite representative or the Technical Service group at 800.628.5084 with any questions, or if you require additional information.

TECH TIP:

Any substance that comes into contact with polycarbonate should be checked for chemical compatibility. Even if the supplier confirms the material is suitable for polycarbonate. Apply it first to a hidden area to see if there are any adverse effects. However, this could indicate short term effects only. To assess long term effects of a substance on polycarbonate, laboratory testing is strongly suggested or consult with the Technical Service group if any doubt exists about a new substance.

CHEMICAL / ENVIRONMENTAL RESISTANCE

Legend

Explanation of the symbols:

- + Resistant
- Partially resistant
- Not Resistant

Chemicals

Acetaldehyde	-	Chlorbenzene	-
Acetic acid, up to 10% solution	+	Chlorine gas, dry	○
Acetone	-	Chlorine gas, wet	-
Acetylene	+	Chlorine lime slurry	+
Acrylonitrile	-	Chlorine lime, 2% in water	+
Allylalcohol	○	Chloroform	-
Allyl alcohol	-	Chrom alum, saturated aqueous solution	+
Alum	+	Chromic acid, 20% in water	+
Aluminum chloride, saturated aqueous solution	+	Citric acid	+
Aluminum oxalate	+	Copper sulphate, saturated aqueous solution	+
Aluminum sulphate, saturated aqueous solution	+	Cresol	-
Ammonia	-	Cupric chloride, saturated aqueous solution	+
Ammoniacal liquor	-	Cuprous chloride, saturated aqueous solution	+
Ammonium chloride, saturated aqueous solution	+	Cyclo hexane	-
Ammonium fluoride	+	Cyclo hexanol	○
Ammonium nitrate, saturated aqueous solution	+	Cyclo hexanone	-
Ammonium sulphate, saturated aqueous solution	+	Decalin	+
Ammonium sulphide, saturated aqueous solution	-	Dekaline	+
Amylo acetate	-	Diamyl phthalate	-
Aniline	-	Dibutyl phthalate (plasticizer)	-
Antimony chloride, saturated aqueous solution	+	Diethylene glykol	+
Arsenic acid, 20% solution	+	Diethylether	-
Benzaldehyde	-	Diglycolic acid, saturated aqueous solution	+
Benzene	-	Dimethyl formamide	-
Benzine	+	Dinonyl phthalate (plasticizer)	○
Benzoic acid	-	Dioctyl phthalate (plasticizer)	○
Benzyl alcohol	-	Dioxane	-
Borax, saturated aqueous solution	+	Diphyl 5, 3	○
Boric acid	+	Ether	-
Bromic benzene	-	Ethyl alcohol, 96% pure	+
Bromine	-	Ethyl amine	-
Butane (liquid or gaseous)	+	Ethyl bromide	-
Butyl acetate	-	Ethylene chlorohydrine	-
Butyl acid	-	Ethylene chloride	-
Butanol	+	Ethylene glykol	+
Butylene glycol	+	Ferritrichloride, saturated aqueous solution	+
Butyric acid	-	Ferro bisulphate	+
Calcium chloride, saturated aqueous solution	+	Ferrous sulfate	+
Calcium hypochloride	+	Formaline, 10%ig	+
Calcium nitrate, saturated aqueous solution	+	Formic acid, 30%	○
Calcium-soap, fat/pure	+	Gasoline	+
Carbon acid, wet	+	Glycerine	○
Carbon bisulfate	-	Glycol	+
Carbon dioxide	+	Heptane	+
Carbon monoxide	+	Hexane	+
Caustic potash	-	Hydrochloric acid, 20%	+
Caustic soda	-	Hydrochloric acid, conc.	-
		Hydrofluoric acid, 5%	+

CHEMICAL / ENVIRONMENTAL RESISTANCE

Hydrofluoric acid, conc.	-	Potassium perchlorate, 10% in water	+
Hydrofluorosilicic acid, 30%	+	Potassium permanganate, 10% in water	+
Hydrogen peroxide, 30%	+	Potassium persulphate, 10% in water	+
Iodine	-	Potassium rhodanide, saturated aqueous solution	+
Isoamyl alcohol	O	Potassium sulphate, saturated aqueous solution	+
Isopropyl alcohol	+	Propane gas	+
Lactic acid, 10% in water	+	Propargyl alcohol	+
Lead tetraethylene, 10% in gasoline	O	Propionic acid, 20%	+
Lighting gas	+		
Ligroin (hydrocarbon compound)	+	Propionic acid, conc.	-
Lime milk, 30% in water	O	Propyl alcohol	+
Magnesium chloride, saturated aqueous solution	+	Pyridine	-
Magnesium sulphate, saturated aqueous solution	+	Resorcin oil solution, 1%	+
Manganous sulphate, saturated aqueous solution	+	Carbon disulphide	-
Mercurio chloride, saturated aqueous solution	+	Hydrogen sulphide	+
Mercury	+	Soda	+
Methacrylic acid-methyester (MMA)	-	Sodium bicarbonate, saturated aqueous solution	+
Methane	+	Sodium bisulphate, saturated aqueous solution	+
Methanol	-	Sodium bisulphide, saturated aqueous solution	+
Methyl amine	-	Sodium carbonate, saturated aqueous solution	+
Methyl ethyl ketone (MEK)	-	Sodium chlorate, saturated aqueous solution	+
Methylene chloride	-	Sodium chloride, saturated aqueous solution	+
Methyl methacrylate	-	Sodium hydroxide	-
Nitric acid, 10%	+	Sodium hypochloride, 5% in water	+
Nitric acid, 10-20%	O	Sodium sulphate, saturated aqueous solution	+
Nitric acid, 20%	-	Sodium sulphide, saturated aqueous solution	O
Nitric Gas, dry	-	Styrene	-
Nitrobenzene	-	Sublimate, saturated aqueous solution	+
Oxalic acid, 10% in water	+	Sulphur	+
Oxygen	+	Sulphur dioxide	O
Ozone	+	Sulphuric acid, 50%	+
Pentane	+	Sulphuric acid, 70%	O
Perchloric acid, 10% in water	+	Sulphuric acid, conc.	-
Perchloric acid, concentrated	O	Sulphurous acid, 10%	-
Perchloro ethylene	-	Sulphuryl chloride	-
Perhydrol, 30%	+	Tartaric acid, 10%	+
Petroleum	O	Tetrachlorocarbon	-
Petroleum ether	O	Tetrachloroethane	-
Petroleum spirit	+	Tetrahydrofurane	-
Phenol	-	Tetraline	-
Phenyl ethyl alcohol	-	Thiophene	-
Phosphor trichloride	-	Toluene	-
Phosphoric acid, conc.	+	Trichloro acetic acid, 10%	O
Phosphoric oxichloride	-	Trichloroethyl amine	-
Potassium aluminum sulphate, saturated aqueous solution	+	Trichloroethyl phosphate (plasticizer)	O
Potassium bichromate, saturated aqueous solution	+	Trichloroethylene	-
Potassium bromide, saturated aqueous solution	+	Tricresyl phosphate (plasticizer)	-
Potassium carbonate, saturated aqueous solution	+	Urea, saturated aqueous solution	+
Potassium chloride, saturated aqueous solution	+	Water	+
Potassium cyanide	-	Xylene	-
Potassium hydroxide	-	Xylol	-
Potassium metabisulphide, 4% in water	+	Zinc chloride, saturated aqueous solution	+
Potassium nitrate, saturated aqueous solution	+	Zinc oxide	+
		Zinc sulphate, saturated aqueous solution	+

CHEMICAL / ENVIRONMENTAL RESISTANCE

Disinfectants & Germicides

Accel TB	-
Baktol®, 5%	+
Carbolic acid	-
Chloroamine	+
Clorox® BROAD SPECTRUM Quaternary Disinfectant Cleaner	-
Clorox® Healthcare FUZION Cleaner Disinfectant	-
Clorox® Healthcare Bleach Germicidal Cleaner	-
DDT	-
Delegol®, 5%	+
Dimamin T, 5%	O
Hydrogen peroxide	+
Iodine tincture	O
Lysoform, 2%	+
Lysol® Brand III Disinfectant Spray (original)	-
Maktol®	+
Merfen®, 2%	+
Oktozon®, 1%	+
PDI® Super Sani-Cloth® Disposable Wipes	-
Perhydrol	+
PeridoxRTU® Sporicidal Disinfectant	-
Resorcinol solutions, 1%	+
Safetec Surface Safe Wipes	-
Sagrotan®, 5%	O
Spirit, pure	+
Steriplex® SD	-
Sublimate	+
TB-Lysoform	-
Trosilin G extra®, 1, 5%	+
ZEP® 40 Non-Streaking Cleaner	-
ZEP® SPIRIT II	-
Zephirol®	O

Pharmaceuticals and cosmetics

Blood plasma	+
Delial-Sunmilk®	+
Botanicare® Hydroplex	+
Iodine tincture	O
Klosterbalsam	+
Lanoline	+
Menthol, 90% in Alcohol	O
Nail polish	-
Nail polish remover	-
Odol-mouthwash®	+
Periston blood substitute®	+
Vaseline	+
Vicks® VapoRub®	+
ZEP® SPIRIT II	-
Zephirol®	O

Nutrition

Allspice	-
Apple juice	+
Beef sebum	+
Beer	+
Beets syrup	+
Brandy, 38%	+
Butter	+
Chocolate	+
Cinnamon	+
Clove	-
Cod-liver oil	+
Coffee	+
Common salt	+
Fish	+
Fruit juice	+
Fruit syrup (Raspberry)	+
Gherkins	+
Grape sugar	+
Grapefruit juice	+
Juniper berry	+
Lard	O
Linseed oil	+
Liquor	+
Margarine	+
Meat	+
Milk	+
Mineral water	+
Mustard	+
Nutmeg	-
Onion	+
Orange juice	+
Paprika	+
Pepper	+
Rum	+
Salad oil	+
Syrup	+
Sugar solution, saturated aqueous solution	+
Tea	+
Tobacco	+
Tomato juice	+
Tomato puree	+
Vanilla	+
Vegetable juice	+
Vegetable oils	+
Vinegar	+
Vodka	+
Water	+
Wine	+
Worcestershire sauce	+
ZEP® SPIRIT II	-
Zephirol®	O

CHEMICAL / ENVIRONMENTAL RESISTANCE

Oils, fats and lubricants

Aral BG®58	+
Automatic switch grease	+
Baysilon®-silicone oils	+
BP Energol HL 100®	+
BP Energol EM 100®	+
BP H LR 65®	+
Brake fluid (ATE)	+
Burnishing oil Brunofix	+
Camphor oil	-
Cable insulating oil IG 1402	+
Cable insulating oil KH 190	+
Calcium soap fat	+
Castor oil	+
Contact oil 611	+
Diesel oil	O
Drilling oil	-
Esso Estic 42-45®	+
Fish oil	+
Grease R Z Darina®	+
Heating fuel oil	O
Hydraulic oil Vac HLP 16	+
Jet propulsion fuel JP4 (kp 97-209°C)	
Skydrol 500 A®	O

Mobil DTE oil light®	+
Mobil special oil 10 w 30®	+
Molikote®-paste	+
Molikote®-powder	+
Nato-turbine oil 0-250	+
Naphtenic lubricating oil	+
Paraffin oil	+
Polyran® MM25 (lubricating oil)	+
Rape seed oil	+
Renocalor N®	+
Sewing machine oil	+
Shell Spriax 90 EP®	+
Shell Tellus 33®	+
Silicone fluid	+
Sodium soap fat	+
Texaco Regal oil BRUO®	+
Texaco Regal oil CRUO®	+
Train oil	+
Turbo oil 29	+
Shell Tellus 11-33®	O
Turpentine oil	O
Valvoline WA 4-7	O
Varnish	O

Miscellaneous

Battery acid	+
Blood	+
Castor oil	+
Cement	+
Freon® 113	+
Gasoline	O
Natural rubber	+
Oleic acid, conc.	+
Polishing wax	+

Polyethylene	+
Polyvinylchloride, (containing plasticizer)	O
Rain-X Original Glass Treatment	-
Sea water	+
Starch	+
Weak acid >4.7 pH	+
Weak base <9.5 pH	O
Tannic acid	-

Adhesives & Sealing Materials

All-purpose glue	O
Cellux® - adhesive film	+
Gypsum	+
Insulating tape	+
Perbunan C®	+
Putty	+
Rubber (softener-free)	+
Terostat®	+
Tesafilm	+
Tesamoll®	+

Momentive Silpruf 1000-2800 series	+
Serbeseal MP	+
Dow Corning 795	+
Dow Corning 995	+
Parasilico PL (cl.)	+
Proglaze	+
3M 431 -aluminum tape	+
Gerlinger 712 -aluminum tape	+
EPDM, Neoprene, Santoprene® synthetic rubber	
3M VHB Tape	

Washing and cleaning agents

Household soap	+
Dawn®	+
Joy®	+
Palmolive Liquid®	+

Polishing Agents & Antistatics

Antistaticum 58	O
Antistatic C	-
Arquad 18®	O
Delu-Antistatic solution®	+
Persoftal®	+



CLEANING & STORAGE RECOMMENDATIONS

CLEANING & STORAGE RECOMMENDATIONS

TUFFAK cleaning instructions

Periodic cleaning of TUFFAK is recommended to prolong the service life of your material. To minimize the risk of damage, use only compatible household cleaners and correct cleaning procedures as outlined below.

TUFFAK GP polycarbonate mars easily with wiping action. TUFFAK 15, TUFFAK AR, and HYGARD laminate sheets are hard coated, abrasion and mar resistant polycarbonate products that offer a high degree of surface hardness and abrasion resistance. These products provide superior protection against unintentional chemical attack. However, the use of abrasive, gritty cleaners, or hard cleaning implements (e.g., hard brushes, scrapers, squeegees) should be avoided to eliminate the possibility of scratching the coating.

Compatible cleaners

The following cleaning agents are compatible with TUFFAK polycarbonate sheet products when used according to the manufacturer's recommendations:

- » Dawn® Dishwashing Soap
- » Joy®
- » Palmolive Liquid®
- » Ammonia-free glass cleaner (vinegar or isopropanol only)

Dawn and Joy are registered trademarks of Proctor & Gamble, Palmolive is a registered trademark of Colgate Palmolive.

General cleaning instructions:

- » Thoroughly pre-rinse with warm water to loosen and wash away surface residue, grit, and grime.
- » Using a soft microfiber cloth or moist non-abrasive sponge, gently wash with a mild diluted soap or detergent.
- » Rinse thoroughly with lukewarm, clean water. To prevent water spots, thoroughly dry the glazing with a dry soft cloth.

Removing heavy oils and tars:

- » Thoroughly pre-rinse with warm water to loosen and wash away surface residue, grit, and grime.
- » With a 50/50 isopropyl alcohol-water mixture, gently rub the area with a soft non-abrasive cloth.
- » Immediately rinse thoroughly with lukewarm clean water. To prevent water spots, thoroughly dry the glazing with a dry soft cloth.

Removing graffiti, paint, marker, inks, and glazing compounds:

- » Thoroughly pre-rinse with warm water to loosen and wash away surface residue, grit, and grime.
- » Using Naphtha VM&P grade, Isopropyl Alcohol or Butyl Cellosolve™, gently rub the area with a soft, non-abrasive cloth. Do not apply solvent cleaners under direct sunlight or during high temperatures.
- » Immediately rinse thoroughly with lukewarm clean water. To prevent water spots, thoroughly dry the glazing with a dry soft cloth.

Butyl Cellosolve™ is a trademark of DOW.

Novus® 1 and Novus® 2 are registered trademarks of Novus® Plastic Polish.

Removing adhesive-backed labels:

- » Isopropyl Alcohol, Naphtha VM&P grade or Kerosene will help lift stickers and adhesives.
- » Immediately rinse thoroughly with lukewarm clean water. To prevent water spots, thoroughly dry the glazing with a dry soft cloth.

Important reminders

- » Do not clean TUFFAK with any cleaners other than those on the approved, compatible list included in this guide, or those pretested and found compatible.
- » Do not use abrasive cleaners.
- » Do not use high alkaline cleaners (high pH or ammoniated).
- » Do not leave cleaners sitting on TUFFAK for periods of time; rinse off immediately.
- » Do not apply cleaners under direct sunlight or at elevated temperatures.
- » Do not use scrapers, squeegees, razors, or other sharp instruments as they may permanently scratch TUFFAK.
- » Do not dry rub or dry clean TUFFAK, as sand and dust particles clinging to the exterior of the glazing may scratch its surface. An Anti-Static Canned-Air Ionizer can reduce electrostatic charge buildup on TUFFAK, and aids in reducing dirt and dust buildup that can hinder cleaning.

Contact the Plaskolite Technical Service Group at 800.628.5084 with any questions.

TECH TIP:

The edges of coated polycarbonate sheet are not protected with an abrasion and chemical resistant hard coating. Do not allow cleaning solutions and solvents to pool along the edges for any length of time. Always rinse edges thoroughly with generous amounts of lukewarm clean water.

Removing scratches

Deep scratches and gouges made by sharp objects such as keys, screwdrivers, and knives cannot be repaired. Fine scratches may be reduced in severity or cosmetically hidden by using a buffing compound such as NOVUS® 2 Plastic Fine Scratch Remover, followed by a cleaning and polishing agent like NOVUS® 1. However, for abrasion resistant coated products, buffing the surface is not recommended. Buffing these scratched sites worsen the condition and further damage the coating. Once the coating is removed, it cannot be repaired and buffing may optically distort the window.

Sheet storage

TUFFAK sheets must be stored with original masking in a cool, dry and well-ventilated room, at a reasonable constant temperature away from direct sunlight, excessive humidity or rain. Long term exposure to the sun or other heat sources can cause fusing of the protective polyethylene film to the sheet surface, impeding its removal. Sheets are best stored horizontally on the original pallet. Pay attention to avoid pressure on unsupported areas.



CAUTION
DISCONNECT POWER
BEFORE REMOVING
THIS COVER/DOOR

DANGER
HANDS OUT

⚠ DANGER
Keep hands and
fingers away

FABRICATION

FABRICATION - INTRODUCTION

TUFFAK polycarbonate sheets can be cut, sawn, drilled, milled and bent (except hard coated polycarbonate or HYGARD products) easily using standard workshop equipment. However, it is always recommended to use specific tools specially designed for plastics instead of overlapping with wood or metal tools which may be contaminated with cutting oils. TUFFAK products are ideal for fabricating for a wide range of indoor and outdoor applications. It is preferable to leave the protective film masking in position throughout machining to keep the sheet surface in perfect condition.

Cutters

TUFFAK sheet products easily fabricate using standard cutting tools. Carbide-tipped cutters are recommended. Always use properly sized, sharp cutting tools.

Cooling

Cooling TUFFAK sheet while fabricating is not typically required. In the event of localized overheating when fabricating, only use compressed air or water mist. Avoid cutting fluids of any type. The additives in these products are largely incompatible and can cause chemical stress cracking.

Dimensional accuracy

The rate at which TUFFAK sheet expands is higher than materials such as glass and metal. It has a movement rate of 0.060" (1.52mm) per 12 inches (305mm) of linear dimensions, over a 70°F (21°C) temperature change. As a result, the dimensions should always be checked at room temperature.

Protective masking

TUFFAK sheet comes with protective masking. This film guards against surface damage during shipment/handling as well as fabrication. This masking should be left on during fabrication.

Masking cannot withstand direct outdoor exposure for prolonged periods and must be removed soon after installation. If not removed, the film will eventually degrade and may be difficult or impossible to remove. Storing sheet outdoors is not recommended for this reason.

Remove the masking prior to doing any type of heat processing; for further guidance on this subject please contact Plaskolite Technical Service Group for more information.

Basic Rules for Machining TUFFAK

All methods of machining cause local overheating, generating internal stress, which can result in crazing, (very fine cracks) later evolving into larger cracks, during forming or in the presence of solvents, such as during bonding or painting.

Crazing can be significantly reduced if the following general instructions are applied.

1. Proper cooling: Keep the working tools cooled with compressed air or water mist. Beware using coolants that can chemically attack polycarbonate.
2. Swarf removal: Efficiently remove swarf, strings, dust and melted burrs along the edge of a cut line. Machining without suction will cause frequent stops for manually cleaning of debris.
3. Sharpened tools: Use only adequate tools and keep them perfectly sharp.
4. Material support: The sheet should be firmly supported during machining, especially close to the machines area, to avoid vibration of the sheet.
5. Feed rate: The faster the feed rate is, the better the cut. However when the tool exceeds the recommended speed overheating leading to stress generation may happen. Maintain a constant feed rate as much as possible.
6. Rotation plane: Keep the rotation plane of the working tool exactly parallel or perpendicular (depending on the machine used) to the feed direction.

TECH TIP:

Wear eye protection, and ensure equipment has safety guarding. Stock feed rates must be carefully controlled as an excessive rate causes vibration and may crack the part.

SAWING, SHEARING, DRILLING, MILLING, ROUTING, DIE CUTTING/PUNCHING

CIRCULAR SAWING

As shown in the accompanying illustration, use a carbide-tipped, circular saw blade with triple-chip tooth design, which cuts clean and lasts longer than high strength steel. Blade is hollow-ground and slotted for expansion and cooling.

The blade cutting speed should be 5000-6000 ft/min (1524 - 1828M / min), and the table saw setup gap (between saw blade and bed) must be kept to a minimum for clean cuts.

Circular saw blade and cutting

Cutting speed (ft/min) (M/min)	5000 - 6000' (1524 - 1828M)
4" (10.2cm) Blade	8 - 10 teeth/inch (per cm)
8 - 10" (20.3 - 25.4cm) Blades	6 - 8 teeth/inch (per cm)

Triple-chip grind

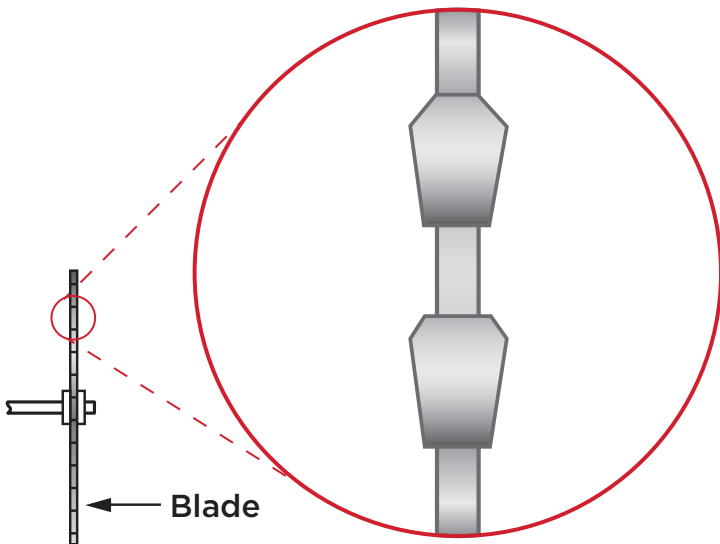

Circular saw troubleshooting

PROBLEM: Melting or Gummed Edges

SUGGESTED SOLUTIONS:

1. Increase blade tooth size
2. Reduce saw speed
3. Increase feed rate
4. Use compressed air to cool blade
5. Inspect blade for sharpness
6. Check blade-fence alignment
7. Reduce number of sheets in stack

PROBLEM: Chipping

SUGGESTED SOLUTIONS:

1. Decrease blade tooth size
2. Increase saw size
3. Provide better clamping/support for sheet stack
4. Reduce feed rate
5. Check blade and arbor for wobble
6. Inspect blade for sharpness

Circular saw blade suppliers:

Dino Saw Company
340 Power Ave.
Hudson, NY 12534
518 828-9942
www.dinosaw.com

General Saw Corp.
2518 Andalusia Blvd.
Cape Coral, FL 33909
800 772-3691
www.peaktoolworks.com

FTM, Inc.
327 Industrial Drive
Placerville, CA 95667
530 626-1986
www.fabricationtoolsandmaterials.com

FABRICATION

BAND SAWING

Band sawing is preferred for cutting contour and irregular shapes.

General guidelines:

- » Use precision or standard blades for sheet and parts made from thin gauge
- » Use buttress or skip-tooth blades for sheets thicker than 1/8 inch (3 mm)
- » Choose band-saw blades with generous set to reduce friction and heat buildup
- » Cool the cut junction with air or a water mist
- » Control the feed rate carefully to prevent binding and gumming
- » Use saw guides whenever possible

Band saw troubleshooting

PROBLEM: Melting or Gummed Edges

SUGGESTED SOLUTIONS:

1. Increase blade tooth size
2. Reduce saw speed
3. Use compressed air to cool blade
4. Check blade sharpness

PROBLEM: Chipping

SUGGESTED SOLUTIONS:

1. Decrease blade tooth size
2. Slow down stock feed rate
3. Provide better clamping/support to eliminate vibration
4. Check blade sharpness

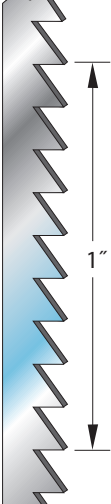

Band saw blade design

8 - 12 teeth per inch (per cm)

Part thickness (inch)	Tooth type	Pitch (teeth/inch, cm)	Band speed (ft, M/min)
< 1/8 (3mm)	Precision or Standard	8 - 12	2,000 (607)
1/8 - 1/4 (3mm-6mm)	Buttress or Skip Tooth	5 - 6	1,500 (457)
> 1/4 (6mm)	Buttress or Skip Tooth	3 - 4	1,000 (305)

SHEARING

TUFFAK sheet up to 1/4" (6mm) thick can be sheared. Sheared edges have a burred and rolled cut that is highly stressed and should be saw trimmed to prevent future cracking.

Important considerations for shearing:

- » A guillotine blade on a fixed bed cuts a cleaner edge than a two blade shear
- » 45-degree rake angle blade recommended
- » Clearance between the blade and bed should be no more than 0.001-0.002 inch (0.025- 0.050mm)
- » If cracks develop upon shearing, consider warming the material first; inspect blade
- » Shearing flame retardant product is not recommended as the additives in the sheet reduce its ductility. Warming material may help prevent cracking but does not guarantee success

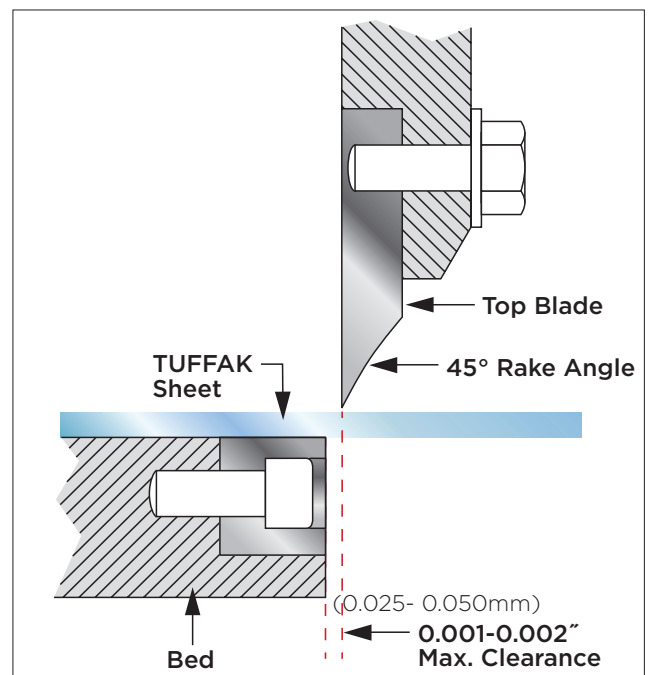

FABRICATION

DRILLING

While standard drills and bits can be used with TUFFAK sheet, those specifically designed for plastics perform with greatest precision. They have wide, polished flutes to reduce friction, as well as spiral or helix designs to remove chips quickly.

- » Drill-point angles typically range between 60 and 90 degrees
 - Smaller angles for smaller holes and larger angles for larger holes
- » Drilling speeds range between 100 and 200 feet (30M and 61M) per minute, however feed rates can be increased under ideal conditions of proper cooling, sharp drills, and efficient chip removal

General guidelines for drilling TUFFAK sheet:

- » Use carbide-tipped drills, they resist gumming and maintain edge sharpness longer than standard drills
- » Drill holes slightly oversized
- » Allow distance between sheet edge and drilled hole to be at least two times the diameter of hole
- » Do not use cutting fluids; use cool forced air or clean water mist for cooling bit.

Countersink is not recommended, counter-bore is acceptable. A counterbore usually has more holding strength compared to a countersink hole because the force applied by the cap screw head is parallel to the axis. The force applied by the screw or bolt is distributed evenly over a larger surface. This is not the case with a countersunk hole, which has tapered sides and forces material out, against the sides creating undue stress.

Drill bit design

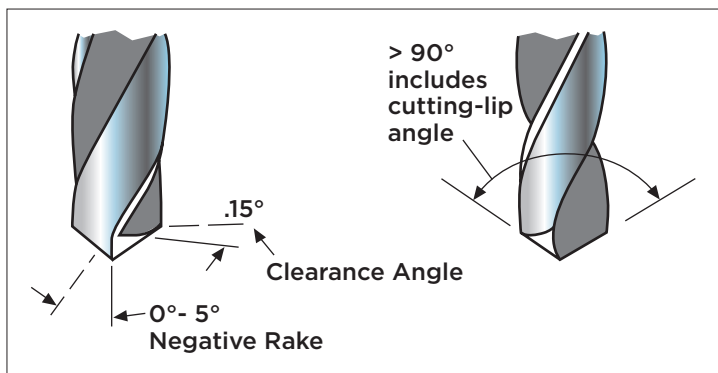

Common drilling problems and remedies

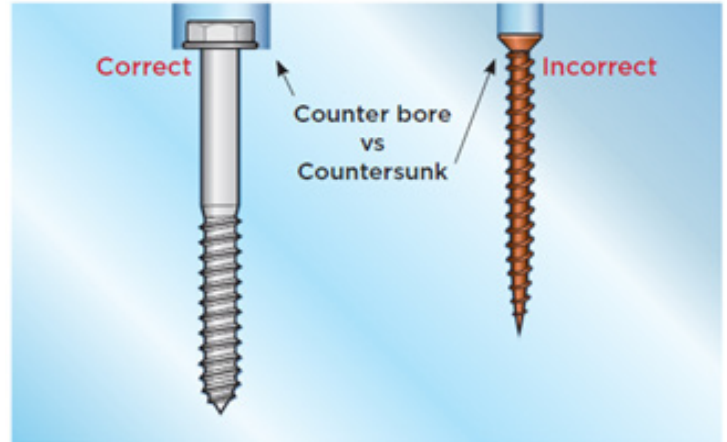

Drill hole minimum distance from edge of sheet

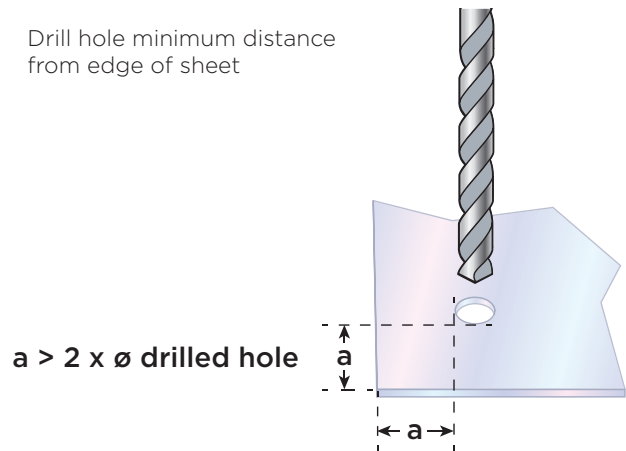

Drill (inch, mm)	Feed (inch, mm/rev)	Drill speed (RPM)
Up to 1/8 (3mm)	0.001 - 0.002/0.025-0.051	1750
1/8 to 1/4 (3-6mm)	0.002 - 0.004/0.051-0.10	1750 - 1500
1/4 to 1/2 (6-12.7mm)	0.004 - 0.006/0.10-1.5	1500 - 500
1/2 to 1 (12.7-25.4mm)	0.006 - 0.008/1.5-2.0	500 - 350

Problem	Probable cause	Remedy
Hole too large	1. Unequal angle on length of cutting edge 2. Burr on drill	1. Properly regrind drill bit
Rough or burred hole	1. Dull drill 2. Improperly ground drill 3. Too fast feed	1. Regrind properly 2. Reduce feed
Breaking of drill	1. Feed too fast in relation to spindle speed 2. Dull drill-grabs in work 3. Inadequate chip cleaning	1. Reduce feed or increase speed 2. Regrind drill bit 3. Check application setup
Chipping of high-speed drill	1. Improper heat treatment after regrinding 2. Too coarse feed	1. Follow manufacturers' recommendations 2. Reduce feed

Specialty drill bit suppliers:

Onsrud Cutter
1081 S. Northpoint Blvd.
Waukegan, IL 60085
800 234.1560
www.onsrud.com

Craftics, Inc.
2804 Richmond Dr.
Albuquerque, NM 87107
505 338.0005
www.craftics.net

FTM, Inc.
327 Industrial Drive
Placerville, CA 95667
530 626-1986
www.fabricationtoolsandmaterials.com

FABRICATION

MILLING

Milling is used to remove large volumes of plastic with relatively high accuracy and precision. Mounted in a drill press, an end mill can plunge repeatedly to a preset depth to produce parts that are flush and smoothly trimmed. For best results, use high-speed end mills with four cutting flutes and a 15-degree rake angle. Always keep mills sharp and well-polished to reduce friction.

Milling TUFFAK sheet typically works best at feed speeds of 5-10 inches (12.7-24.5cm)/minute and cutting speeds of between 100-200 (254-508cm) inches, cm/minute.

Carbide cutters generally provide smoother finishes and allow for higher feed rates. Special cutters designed specifically for plastics produce the smoothest finishes at the fastest feed rates. Check with your cutter supplier for the latest designs for polycarbonate.

Consider the following when milling TUFFAK sheet:

- » Excessive feed rates can cause rough surfaces
- » Insufficient feed rates can generate too much heat and cause part melting, distortion or poor surface quality
- » Compressed air stream or water mist helps to remove heat and prevent buildup
- » Improper milling can induce high stress levels, causing future problems

TECH TIP:

Consider annealing milled parts in cases where the machining stresses are known to be high.



FABRICATION

ROUTING

Router cutting produces a smooth edge on TUFFAK sheet and easily cuts curved or irregular shapes. Use a recommended router speed of 20,000-25,000 rpm, with straight 2- or 3-fluted carbide-tipped or high-speed bits with diameters 1/4 inch to 1/2 inch (6-12.7mm).

Do not use cooling solutions or lubrication oils that may cause chemical attack on polycarbonate. Use compressed air or clean water mist for cooling bit.

General guidelines for router cutting TUFFAK sheet:

Router bit design	
Clearance angle	5 - 10°
Rake angle	0 - 10°
Cutting speed (rpm)	20,000 - 25,000

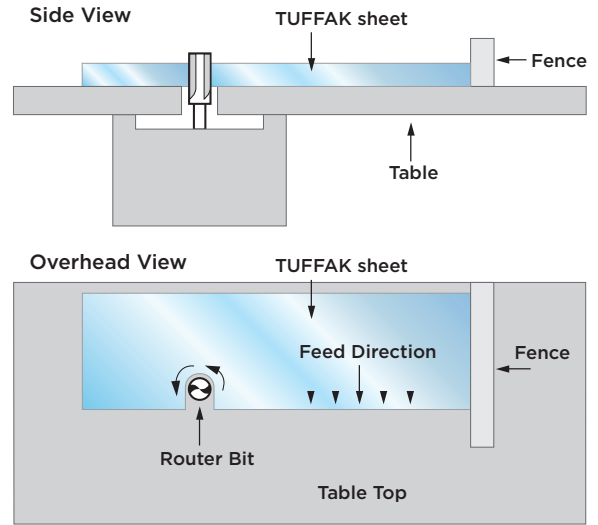

Important: Feed the sheet against the router bit rotation and use a fence for sizing when making straight cuts.

Specialty router bit suppliers:

Onsrud Cutter
1081 S. Northpoint Blvd.
Waukegan, IL 60085
800 234.1560
www.onsrud.com

Boshco, Inc.
2 Sterling Road
North Billerica, MA 01862
978 667.1911
www.boshco-dustek.com

Dino Saw Company
340 Power Ave.
Hudson, NY 12534
518 828-9942
www.dinosaw.com

DIE CUTTING / PUNCHING

Types of dies used in cutting TUFFAK sheet include steel-rule, punch and clicker in gauges up to 0.080 inch (2.0mm). Steel-rule dies trim lighter-gauge parts and clicker dies perform heavier-gauge cuts and continuous cuts in sheet. To obtain a clean cut in most applications, maintain a clearance between the punch and die of about 0.005 inches (0.13mm).

General guidelines when die cutting, punching or blanking TUFFAK sheet:

- » For best results, consider warming the part first before die cutting, punching or blanking
- » Maintain sharp cutting edges for cleanest cut and to avoid creating notches and scratches that could later act as stress concentrators
- » Avoid sharp radii in the corners of non-circular cut-outs
- » Die cutting, punching or blanking parts made of flame retardant grade sheet is not recommended

Use 3 pt (0.042", 1.1mm) thick steel to fabricate steel-rule die. Flush or center bevel-ground rule provides a clean cut. Facet-ground steel rule is used to cut >0.060 inch (1.52mm) TUFFAK sheet. The center bevel rule is the most common and provides the longest life in terms of wear. Cleaner cuts can be attained by using a facet bevel rule. The longer bevel reduces material displacement, especially with thick material, while the broad tip remains sharp. The flush bevel rule also provides clean cuts, but has a weak tip that is susceptible to roll-over.

To maximize both cut quality and rule longevity, the side bevel rule is recommended.

Sanding & Polishing

All cutting methods described above may render saw marks, rough edges, and corners. Apart from being a cosmetic deficiency may be a source of sheet weakness leading to crazing and cracking under end use. It is recommended to smooth edges and corners by sanding and polishing. Sandpaper with 400-500 grit is recommended. Stationary and portable sanding machines with rotating calico mops, muslin, or felt can be used to effectively polish TUFFAK sheets.

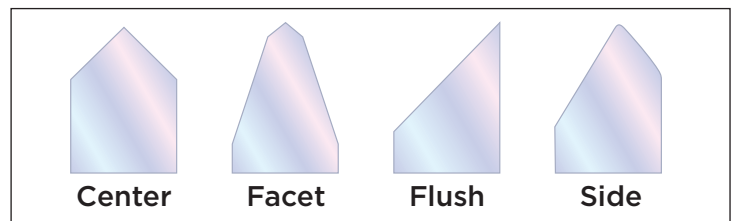

Laser Cutting

TUFFAK can lead to slight discoloration in the cut edge. Contact your laser equipment manufacturer for additional advice on laser settings for cutting or marking of polycarbonate. Adhere to proper safety procedures when laser cutting. The work should be performed in a space with exhaust hoods and good ventilation.

TECH TIP:

TUFFAK sheet should be stored in a well-protected, ventilated area with no direct exposure to sunlight or harsh weather conditions. If temporarily stored outdoors, sheets should be covered with a heat reflecting, opaque covering.



FABRICATION - LAMINATE & HEAVY GAUGE SHEET

HYGARD CG .375

HYGARD CG .750

HYGARD CG .500

HYGARD BR 1.250

HYGARD BR 1.000

HYGARD

FABRICATION – LAMINATE & HEAVY GAUGE

HYGARD® laminates and TUFFAK WG and MG plate products are designed for heavy fabrication.

It is possible to fabricate parts with tight tolerance design using standard cutting tools. Use carbide-tipped cutters for greater durability and a cleaner cut edge. Leave the masking on the product while fabricating to protect against surface damage. Remove masking soon after installation as prolonged outdoor exposure degrades the film making it difficult or impossible to remove.

Proper fabricating practices are especially important when cutting parts intended for security applications. This ensures product integrity with respect to strength properties and performance ratings. Sharp cutting tools are important, as is feed rate control. To avoid material overheating, decrease cutting speed and feed rate.

CIRCULAR SAWING

Use a carbide-tipped, circular saw blade with triple chip tooth design. It allows for cleaner cuts and greater durability than high-strength steel. Blade is hollow-ground, and slotted for expansion and cooling. Recommended blade cutting speed is 5000-6000 ft/min (25-30m/s).

TECH TIP:

The edges of HYGARD® laminates are not protected with abrasion and chemical resistant hard coating. Do not allow cleaning solutions and solvents to pool along the edges for any length of time. Always rinse edges thoroughly with generous amounts of lukewarm, clean water.

Circular saw blade and cutting

Cutting speed (ft, M/min)	5000 - 6000 (1524 - 1828M)
Blade	-8 teeth/inch, cm

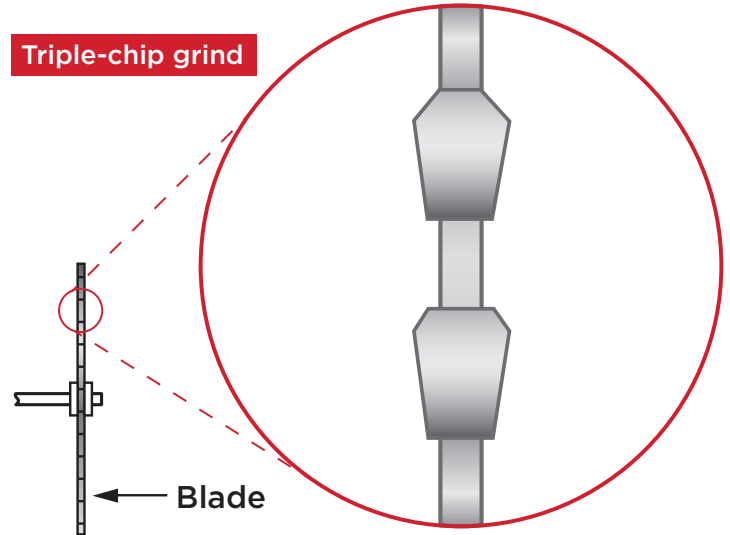

Circular saw troubleshooting

PROBLEM: Melting or Gummed Edges

SUGGESTED SOLUTIONS:

1. Increase blade tooth size
2. Reduce saw speed
3. Increase feed rate
4. Use compressed air to cool blade
5. Inspect blade for sharpness
6. Check blade-fence alignment
7. Reduce number of sheets in stack

PROBLEM: Chipping

SUGGESTED SOLUTIONS:

1. Decrease blade tooth size
2. Increase saw size
3. Provide better clamping/support for sheet stack
4. Reduce feed rate
5. Check blade and arbor for wobble
6. Inspect blade for sharpness

FABRICATION – LAMINATE & HEAVY GAUGE

BAND SAWING

HYGARD laminates, TUFFAK WG and MG products, can be band saw cut with blades having 8-12 teeth per inch, cm. Carefully choose feed rates and blade speed to avoid gumming or melting the plastic edge.

Pitch(teeth/in,cm)	8 - 12
Band speed (ft, M/min.)	2500 - 3000 762-914
Blade set (inch, mm)	0.02-0.03 (0.51-0.76mm)

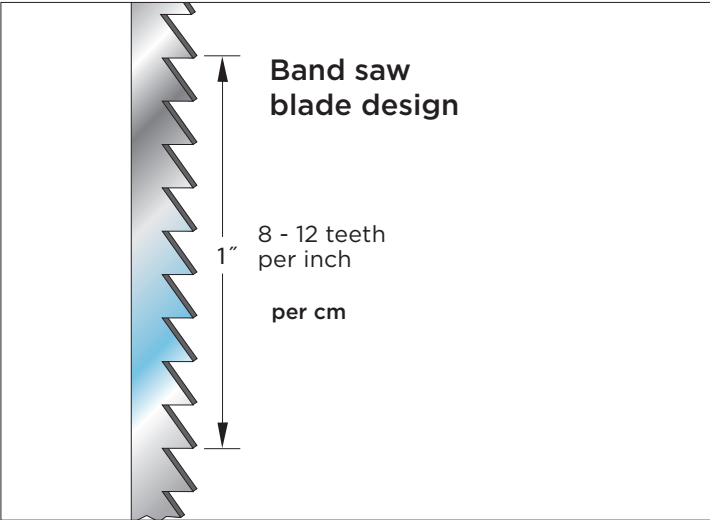

TECH TIP:

Solvent polishing edges of a laminated sheet is not recommended due to the possibility of the TPU bonding layer absorbing the solvent and swelling, resulting in the potential delamination of the product. Microcracking may also occur along solvent polished edges.

TECH TIP:

Laser cutting of HYGARD laminates is not recommended due to increased stress level and higher risk for discolored edges. Water jet cutting of laminates is not recommended due to the potential for delamination.

DRILLING

While standard drills and bits can be used when fabricating HYGARD laminates, TUFFAK WG and MG products, those specifically designed for use with plastics perform with greater precision. Drills for plastics generally have wide, polished flutes to reduce friction, as well as spiral or helix designs to remove chips quickly.

- » Use drill-point angles larger than 90 degrees

Drill bit design

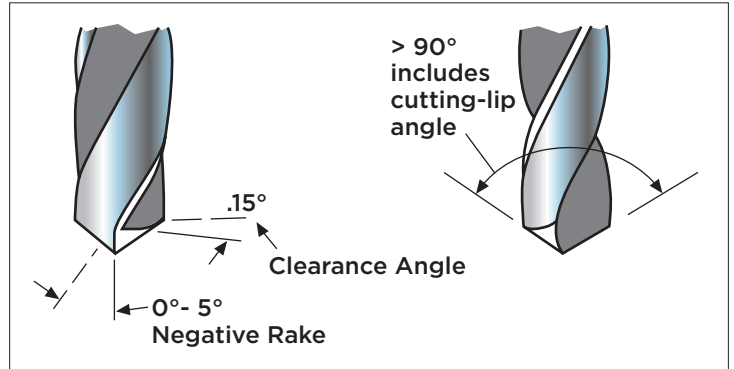

General guidelines for drilling HYGARD laminates, TUFFAK WG and MG:

- » Use carbide-tipped drills, they resist gumming and maintain edge sharpness longer than standard drills
- » Avoid cutting fluids; most are not compatible with polycarbonate
- » Cool work if necessary by forced-air stream
- » Avoid drilling into the edge of laminated sheets due to possible loss of interlayer adhesion

Use sharp drills for cleanest cut and frequently clear the hole of chips. Avoid overheating as stress buildup in the material may have an adverse effect on mechanical properties compromising product performance and reliability. If drilling holes, place them no closer than 2 times the diameter of the hole from the edge. Avoid holes in parts intended for ballistic rated applications.

Hole diameter	Drill speed (rpm)
1/8" (3mm)	1750
1/4" (6mm)	1050 - 1500
1/2" (12.7mm)	350 - 500

FABRICATION – LAMINATE & HEAVY GAUGE

MILLING/ROUTING

To cut clean edges on HYGARD laminates and TUFFAK WG and MG, use straight, 2-3 fluted carbide tipped or high-speed bits, and router speeds of 20,000- 25,000 rpm. Feed sheet against the router bit rotation at a controlled rate to avoid overheating, minimize vibration and produce a smooth part edge. Use a fence for sizing when making straight cuts.

Summary on cutting:

- » Use only sharp cutters
- » Drill holes slightly oversized
- » Drill holes off sheet edge by distance at least 2 times diameter of hole
- » Countersink is not recommended, counter-bore is acceptable in heavy gauge solid sheet
- » Countersink and counter-bore is not recommended for Hygard laminates
- » As cooling medium use forced air, not cutting fluids
- » Do not allow material to overheat
- » Cut edges must be smooth; sand coarse surfaces and chatter marks
- » Leave masking on product during fabrication, remove soon after installation
- » Use cleaners compatible with polycarbonate. If unsure, consult with manufacturer before use

FRAME DESIGN

Select a metal frame that matches the same level of security-rated protection as the specified HYGARD laminate.

Corner design

Mitered corners require added bracing. Attach metal angle bracing at the corners to strengthen the overall frame. For optimal frame design, use a continuous metal extrusion.

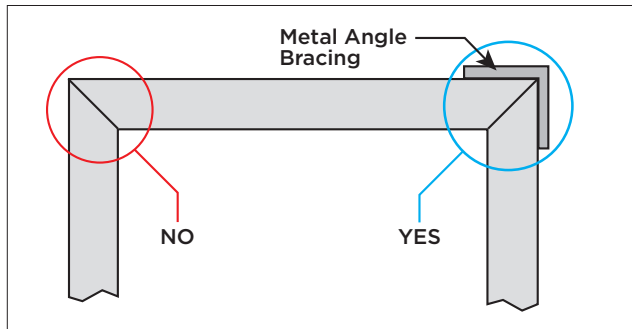

Product performance relies heavily on the method of attachment, the assembly and the potential for thermal expansion.

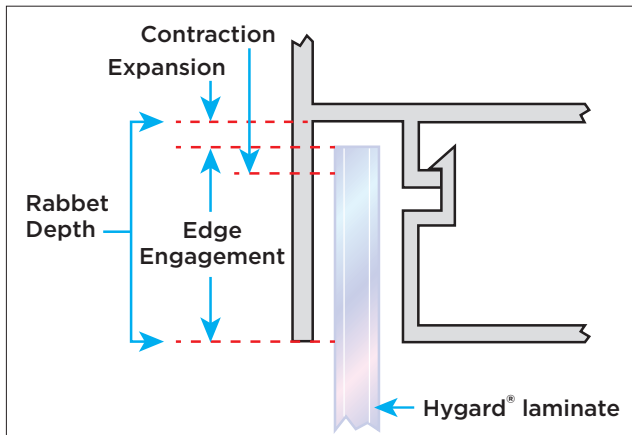

Glazing recommendations

- » Frame system must meet or exceed HYGARD laminate ballistic rating
- » HYGARD laminate dimension must allow for at least 1 inch,(2.54cm) edge engagement
- » Use only gaskets, tapes and sealants compatible with polycarbonate
- » Use setting block strips of polycarbonate, EPDM, neoprene or Santoprene® synthetic rubber
- » Remove protective masking soon after completing the installation, as prolonged exposure to the outdoors will degrade the film making it difficult or impossible to remove
- » Santoprene® is a registered trademark of Exxon Mobil Corporation



THERMOFORMING

THERMOFORMING

Thermoforming is a cost-effective and practical processing method for producing three-dimensional shapes from a flat thermoplastic sheet using heat and pressure. Thermoformed parts can be found across transportation, signage, architectural, specialty and industrial markets.

Known for its low tooling cost and moderate equipment investment, thermoforming is most economical where production volumes are 10,000 parts per year or less. It allows for great design flexibility, and serves as a practical means for prototyping and pre-production trialing of injection molded applications.

PRODUCT GUIDE: FORMABILITY

TUFFAK product	Vacuum forming	Drape forming	Line bending
GP	*	*	*
DX-NR	*	*	*
FC	-	*	-
FI	*	*	*
LF	*	*	*
LD	*	*	*
Lumen XT	*	*	*
OP	*	*	*
NR	*	*	*
SL	*	*	*
SK	*	*	*
UV	*	*	*

THERMOFORMING

Pre-drying TUFFAK sheet

Prior to thermoforming, TUFFAK sheet must be pre-dried to prevent its physical properties from being compromised. Without pre-drying, the high processing temperatures may vaporize the small amount of moisture absorbed in the polycarbonate, causing air bubbles or voids in the thermoformed part.

Pre-dry TUFFAK at 250°F, (121°C) in an air circulating oven equipped with a vent to properly discharge any moisture removed from the sheet. Drying at lower temperatures requires a longer time to thoroughly dry the sheet.

Remove the protective masking from the sheet prior to pre-drying, and hang or rack in the oven with a 1-inch (25.4mm) separation to allow for adequate air exposure.

Note: sheets stacked without air spacing will not dry.

While properly dried TUFFAK sheets will remain dry for approximately eight hours (or less in humid climates and conditions), Plaskolite recommends that sheets be processed as soon as possible upon removal from the oven.

Registration or distortion thermoforming

Registration forming, also referred to as distortion thermoforming, is the process of taking a distorted printed plastic sheet and vacuum forming the image or picture over the thermoformed mold. This allows the initial distorted image to appear in corresponding areas of mold resulting in a non-distorted, three-dimensional image.

TECH TIP: Plaskolite has developed special PE masking film that can be left on the sheet during forming. However, always remove masking from the mold side to prevent it sticking to the mold. If performing deep draws, it is recommended to remove the masking before thermoforming. Printed PE masking can cause ghosting and water marks of the logo on the formed sheet. Remove printed masking before thermoforming.

Drying times/hours

Gauge	250°F (121°C)	180°F (82°C)
0.093" (2.36mm)	4	8
0.118" (3mm)	4	14
0.177" (4.5mm)	12	30
0.236" (6mm)	24	50

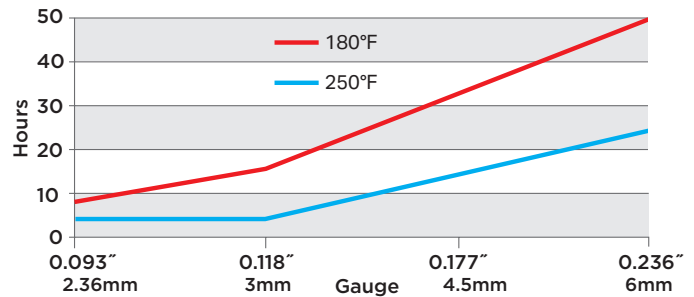

Drying Oven Suppliers
 Wisconsin Oven
www.wisoven.com
 2675 Main Street
 East Troy, WI 53120
 262.642.3938

David Weisman LLC (Weisman Ovens)
dave@daveweisman.com
www.daveweisman.com
 203.322.9978

Sibe Automation
www.sibeautomation.com
 1521 SW 12th Ave
 Ocala, Florida
 678.860.1741

THERMOFORMING

Forming equipment

When setting up the thermoformer, ensure there is adequate clearance between the clamping frame and mold to allow for deep sheet sag. Optimize the platen speed and clamp frame to maximize the processing rate.

Recommended heater elements include ceramic, quartz and halogen. Calrods and nichrome elements can also be used, but typically do not perform as well for heating control. The most efficient thermoforming machines have both top and bottom heater banks for heating polycarbonate sheet. One-sided heating limits forming method options, and tends to overheat the sheet surface and lengthen cycle times. Zone heating allows different banks of heating coils to be controlled separately to produce even heating. Unbalanced heating can lead to a non-uniform temperature profile in the sheet and is evident by uneven sag of the sheet.

The thermoformer's reserve vacuum tank must be of sufficient size, with a pump capable of generating and maintaining a vacuum of 20 inches (50.8cm) Hg pressure throughout the thermoforming cycle.

Forming techniques

Vacuum forming

Selection of a negative tool versus a positive tool depends on the application and is most often determined by the part's appearance or the importance of its fit or assembly. Negative tooling is used where the 'outside' part geometry is more important than the surface finish. Positive tools are for applications needing 'inside' geometry detail and a blemish-free part surface. Make note that any blemish on the tool (negative or positive) will result in an imperfection on the part.

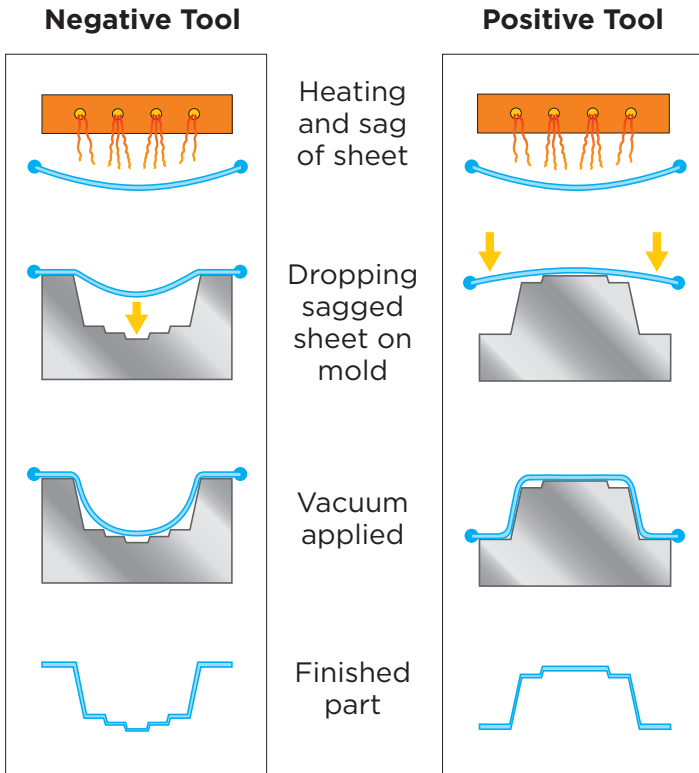

Pressure forming

Pressure forming uses compressed air (up to 100 psi, 0.69 MPa) to force the sheet into the mold. It allows for greater part definition and dimensional control. It also achieves more mold surface detail than other methods for applications that require texturing or lettering, etc.

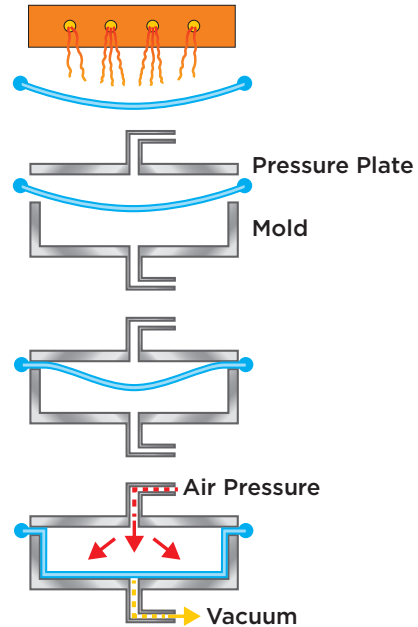

Plug-assisted forming

Plug-assisted forming prevents excessive thinning of material in deep-mold cavities. A plug-assisted formed part has more uniform thickness in the walls than a part produced by typical, single-stage vacuum forming.

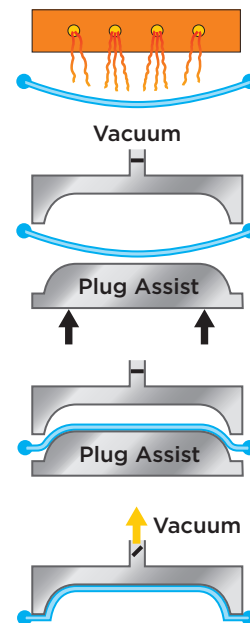

THERMOFORMING

Twin sheet forming

Twin sheet forming uses two sheets of plastic and two negative molds in a single clamp frame setup. A blow pin is inserted between the sheets, and pumps hot air between them to prevent sticking as they soften and sag. This process requires a two-side heater bank. Twin sheet forming is ideally suited to hollow parts with sealed edges, and parts made of two different materials.

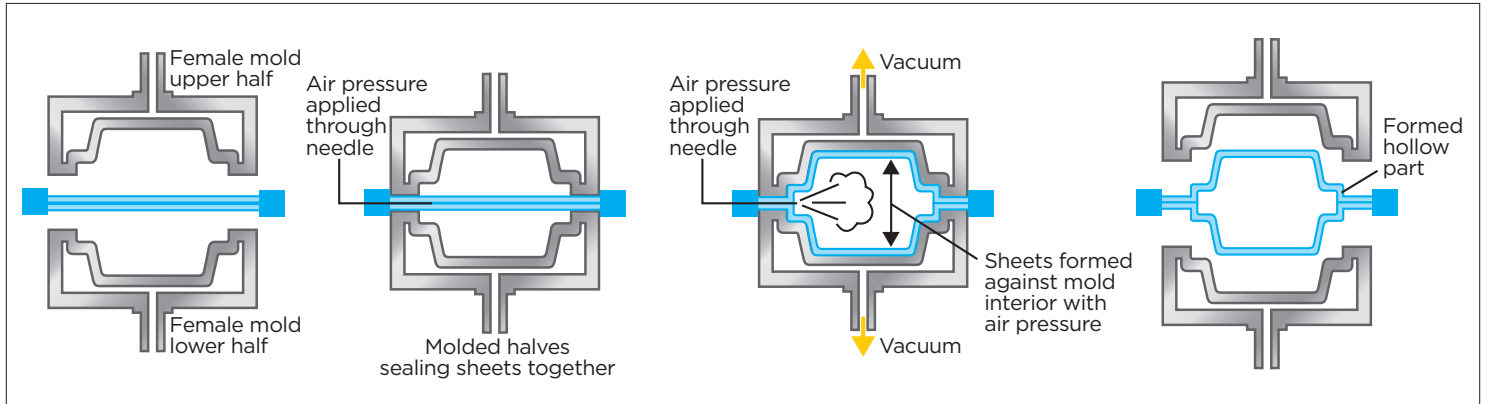

Vacuum forming heating cycle

The target sheet temperature for vacuum forming TUFFAK is between 340°F to 415°F, (171°C - 213°C) depending on gauge. The temperature profile of the sheet will define the resulting sag in the sheet. Maintaining the sag depth and shape provides a visual indicator for forming consistency.

TECH TIP:

Heating from top and bottom shortens cycle time.

Typical heating times for TUFFAK polycarbonate sheet

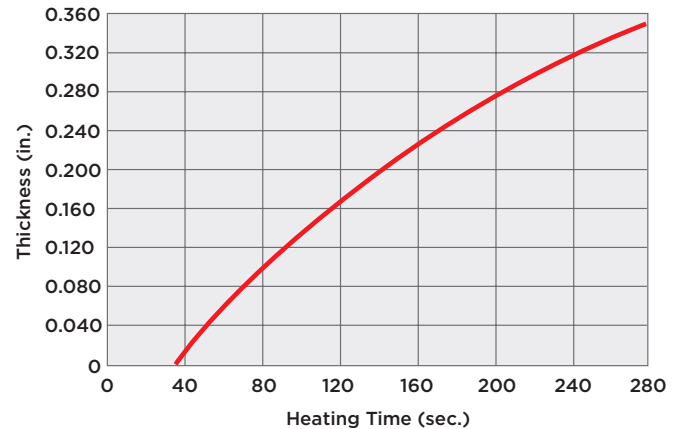

Forming guidelines	
Sheet temperature	
Typical	340°F - 415°F (171°C - 213°C)
Optimum	350°F - 375°F (177°C - 191°C)
Metal mold temperature	
	210°F - 250°F (99°C - 121°C)

Characteristics of thermoforming polycarbonate

While TUFFAK sheet forming characteristics are different than other thermoplastic sheet materials, it outperforms them in production efficiency due to its short heating times, and rapid forming and cooling cycles.

Important reminders for thermoforming TUFFAK

- » Thermoforming temperature is relatively narrow: 340°F - 415°F (171°C - 213°C)
- » Polycarbonate has a glass transition temperature of 298°F. (148°C) Above 311°F (155°C) it begins to soften rapidly.
- » If TUFFAK is not pre-dried, vaporizing moisture absorbed in the sheet can cause air bubbles
- » Polycarbonate cools rapidly. Platen movement and clamp frame travel must operate at appropriate rates without delay.

Sheet sag at forming temperature

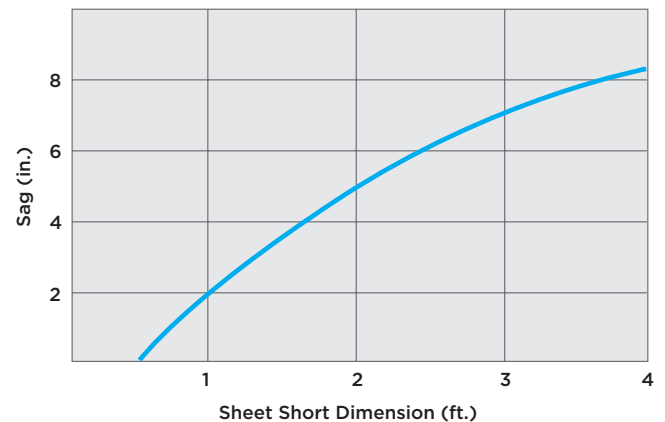

THERMOFORMING

Molds

Used in different forming methods and for production of different products, molds can be made of a variety of materials such as hard wood, aluminum, steel, gypsum, reinforced polyester, or epoxy resins. Laminating and finishing of molds made of other materials other than metal, should produce a surface which will resist wear and prevent distortion by moisture. Aluminum made molds with temperature control will achieve best results for large quantity production. However, for limited or small run volumes, less expensive mold materials like epoxy, fiberglass and wood may be more economical choices. Faults in the finished mold will leave imprints on the molded part. When making a mold, the shrinking properties of polycarbonate must be taken into account. Allow for shrinkage, to make sure the finished part is not smaller than required (see shrinkage instruction). A heated mold will result in better part shaping and will cause a more gradual cooling, reducing induced stress. When molding polycarbonate the mold temperature range should be 210°F - 250°F (99°C - 121°C). Uniform mold heating is necessary to obtain the highest surface detail and optical quality. Keep the mold clean, dirt and dust free. Otherwise, the mold dirt covering will imprint on the molded part. Surface embossing is sometimes used to product patterned surfaces in TUFFAK polycarbonate sheets for application such as lighting fixtures. Surface embossing is produced by pressing the hot sheet against a mold having a textured surface.

Note: Aluminum tools require internal heating to maintain a surface temperature of 210°F - 250°F (99°C - 121°C).

Mold design

Mold shrinkage: Molds require oversizing in their design to compensate for part shrinkage due to cooling. TUFFAK sheet shrinkage is 0.005 - 0.007" per inch (0.13-0.18mm).

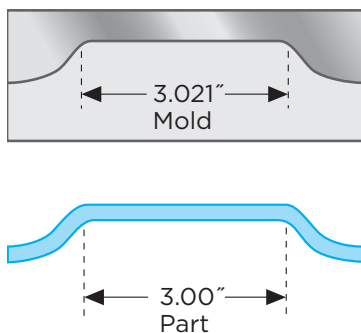

Draft Angles: Draft angles greater than 5° allow for easier removal of the part from the mold.

Radii and Fillets: Use generous radii wherever possible. The radius minimum should be equal to or greater than the starting material thickness, as this minimizes the thinning of the sheet, improves part rigidity and avoids creating a stress riser point. On negative tooling, use corner fillets.

Vacuum Holes: To form sheet rapidly and allow for fast air evacuation, make several holes with small diameters. A 0.030-inch (0.76mm) diameter hole is usually small enough unless the part's wall thickness is less than 0.030" (0.76mm). In concave molds, use air evacuation holes at all deep draw areas, especially around the mold perimeter where the sheet draws last.

Tips on mold design

- » In both positive and negative tooling, keep the diameter of the drilled holes no larger than the thinnest wall section to avoid marking the sheet. Additionally, in negative tooling, design long thin slots for air evacuation.
- » Vapor hone or sand blast metal tools for a uniform surface finish.
- » A highly-polished mold surface is not recommended as it causes sticking and air pockets.
- » The radius minimum should be equal to the sheet's original thickness to relieve stress riser points.
- » Preheat mold. Cold molds can cause surface defects, warping and elevate internal stress in parts.
- » If mold temperature becomes too high during thermoforming, TUFFAK sheet can stick to the mold. Control mold temperature between 210°F and 250°F (99°C - 121°C).

Free forming

Free blown billow forming (as shown below) is a process used for making dome shapes. Apart from the mold, the procedures and equipment are the same as vacuum forming. Billow forming can be done with compressed air or vacuum.

Procedure:

1. Pre-dry TUFFAK sheet following recommendations
2. Preheat clamps and tooling to 240-250°F (116°C - 121°C)
3. Place sheet in clamping frame of thermoformer
4. Heat sheet until uniform sag forms (340-375°F) (177°C - 191°C)
5. Remove heat source
6. Lower pressure box to seal air supply pressure
7. Apply high air pressure initially. As dome takes shape, reduce air pressure
8. When overall height is achieved, maintain positive air pressure until part cools
9. Be sure air source is properly filtered and uniformly dispersed for even formation of dome
10. Utilize electric eye designs or micro switches for height control and consistency
11. Remove and trim part

THERMOFORMING

Free forming

Free blown billow forming (as shown below) is a process used for making dome shapes. Apart from the mold, the procedures and equipment are the same as vacuum forming. Billow forming can be done with compressed air or vacuum.

Procedure:

1. Pre-dry TUFFAK sheet following recommendations
2. Preheat clamps and tooling to 240-250°F (116°C - 121°C)
3. Place sheet in clamping frame of thermoformer
4. Heat sheet until uniform sag forms (340-375°F) (177°C - 191°C)
5. Remove heat source
6. Lower pressure box to seal air supply pressure
7. Apply high air pressure initially. As dome takes shape, reduce air pressure
8. When overall height is achieved, maintain positive air pressure until part cools
9. Be sure air source is properly filtered and uniformly dispersed for even formation of dome
10. Utilize electric eye designs or micro switches for height control and consistency
11. Remove and trim part

Blown dome forming Drawn dome forming

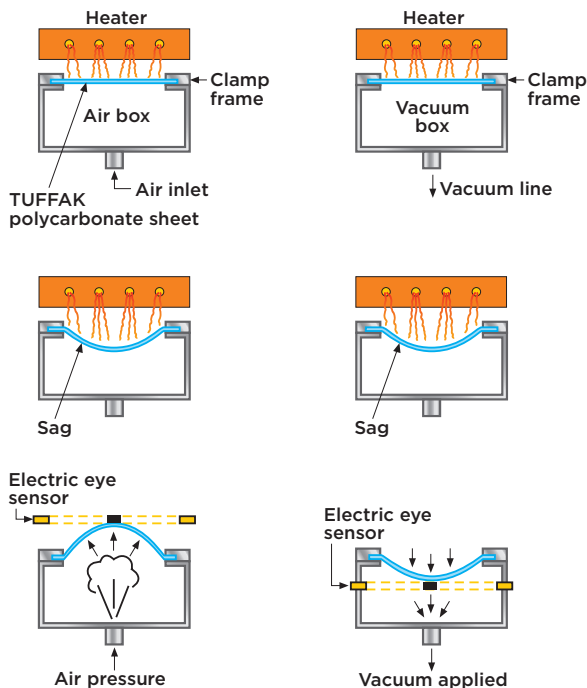

Drape forming

Drape forming requires a felt covered wood tool for making a single radius of curvature parts, or designs of slight contours. Face shields and recreational vehicle windscreens are examples of parts made by this method. The sheet is typically heated on an oven shelf or other means of supporting sheet.

Procedure:

1. Pre-drying TUFFAK sheet is not typically required in drape forming
2. High quality, reproducible forming requires consistent orientation in handling and cutting (top versus bottom), as well as extrusion direction. Do not flip or rotate sheets.
3. Heat oven at 320°F-325°F (160°C - 163°C)
4. Locate the oven shelf at the midpoint of the oven for optimum heat balance. Place a felt covered piece of plywood or other flat rigid, heat-resistant sheet on the oven rack or on a portable oven dolly. Be sure to use a fabric cover to protect the sheet from scratches.
5. Bring TUFFAK sheet to forming temperature in the oven at 320-325°F. (160°C - 163°C) Depending on gauge, this may take several minutes. For example, 0.118" (3mm) gauge sheet takes approximately 3-5 minutes.
6. Manually remove the heated sheet from the oven, and immediately position it over the felt covered mold.
7. Apply pressure at the edges of the sheet to help the sheet take the form of the mold or use matched molds (clamshell molds). Cooling takes about 30-60 seconds.
8. Always wear thermal gloves when handling hot sheet, holding the material by its edges.

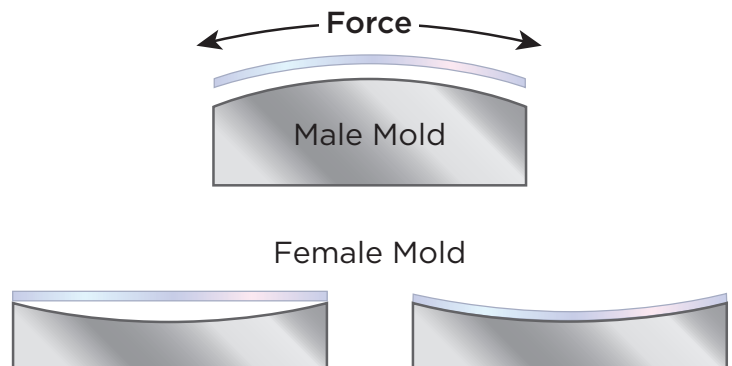

TECH TIP:

Utilize an electronic eye to control height consistency.

TECH TIPS:

- » Line bending works best for lengths of 24" (61cm) or shorter. Longer dimensions require preheating the entire piece to 200°F, 93°C first to prevent warping.
- » For best results with gauges greater than 0.177" (4.5mm), use two-side heating, or turn the part frequently when using a one-side heater. This helps with even heat penetration, preventing moisture bubbling.
- » Additionally, for gauges greater than 0.177" (4.5mm), back route or V-groove with a 1/16-inch (1.52mm) radius to heat cross section. Again, this will help avoid moisture bubbling, while still creating a sharp angle.

THERMOFORMING

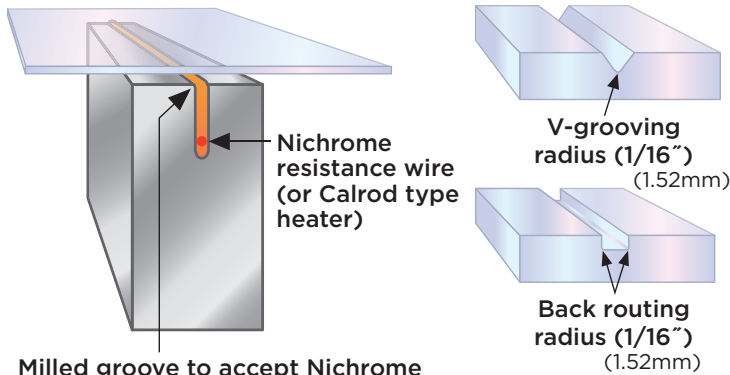

Milled groove to accept Nichrome wire (approximately 1/16 - 1/8" below surface of TUFFAK sheet). Do not allow wire to contact sheet directly.

Heat bending device

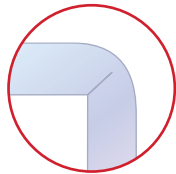

Line bending or strip heating

Line bending, also referred to as strip heating, is a technique for producing linear bends. Generally, pre-drying is not required for line bending TUFFAK sheet gauges up to 0.177". (4.5mm) For thicker sheets, back routing or V-grooving along the bend line is recommended.

Procedure:

1. Remove protective masking in bend area
2. Regulate heating element to 340°F - 365°F (171°C - 185°C)
3. Place sheet over heating element at bend area
4. Allow heat to soften material. The amount of time depends on gauge
5. Remove sheet and make desired bend on a felt covered fixture
6. Bend immediately as polycarbonate cools quickly
7. Allow part to cool on the fixture until set up - about 30 seconds

Note: Some bends may require a degree of over-bend to achieve desired angle.

Free Blown Forming

This method is suitable for high optical quality and limited bubble-like part shapes. Requiring low-cost equipment and short product cycle. This method is the most cost efficient for skylight dome production. The free blown equipment is composed of a plywood board attached to a compressed air source with a pressure control device. It is recommended to preheat the clamps and tool to about 210-250°F, (100-120°C). Frame the pre-dried sheet tightly and heat it until it sages uniformly to 170-190°F, (77-88°C). Gradually increase the air pressure (or vacuum) to the desired point. Maintaining the pressure at the desired point. Allow TUFFAK polycarbonate to cool. Remove from the form after the part has regained its rigidity.

Note:

1. The air pressure controls the height of the dome
2. The shape of the dome can be altered by an imprint and by using a different frame shape
3. The top part of the dome will be thinner than the part close to the base. This may include the coextrusion UV protective layer.
4. Since vacuum is restricted to 1 atmosphere, the use of vacuum free forming will limit the height of the dome.
5. Commonly used air pressure is 3-4.5 atmosphere.
6. Use clean, unfiltered air. Contaminants will impress in the part.
7. Disperse the incoming air, using a protective plate felt or cotton wool. Cold air jet, directed onto the hot polycarbonate sheet will cause rapid local cooling and as a result high stress and non-uniform expansion of the sheet and may induce frozen-in stresses.
8. Forming big domes is better performed when blowing with hot air.

Shrinkage During Drape Forming Applications

After heating, polycarbonate extruded sheets will shrink during the cooling process. The shrinkage is higher in the extrusion direction (MD-machine direction) than in the direction perpendicular to the extrusion (TD- transverse direction). When final part dimensions are critical, forms must be sufficiently oversized to allow for shrinkage when the part cools from forming temperature to room temperature. The table below shows maximum shrinking percentage of polycarbonate sheets:

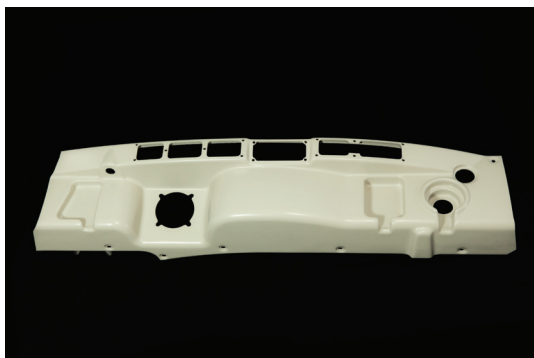

Sheet Thickness (mm)	Shrinkage M.D.	Shrinkage T.D
1.80-2.30	6-7%	0.5%
2.30-3.50	5-6%	0.5%
3.50-4.00	3-4%	0.5%
4.00-6.00	2-3%	0.5%
> 6.00	2%	0.5%

Typical representation of thermoformed part



TROUBLESHOOTING GUIDE

TROUBLESHOOTING GUIDE

Society of Plastics Engineers

Description of Problem	Possible Causes	Possible Corrective Action
Bubbles in formed parts	<ul style="list-style-type: none"> Excessive moisture 	<ul style="list-style-type: none"> Pre-dry sheet as recommended Preheat sheet Heat sheet on both sides Protect sheet from moisture until ready to use
	<ul style="list-style-type: none"> Heating sheet too rapidly 	<ul style="list-style-type: none"> Lower heater temperature Increase distance between heater(s) and sheet Blow air across the sheet's surface during heating
	<ul style="list-style-type: none"> Uneven sheet heating 	<ul style="list-style-type: none"> Check heater output and/or power consumption Use pattern heating Screen by attaching baffles, masks, or screening
Crazed or brittle parts	<ul style="list-style-type: none"> Mold too cold 	<ul style="list-style-type: none"> Increase mold temperature
	<ul style="list-style-type: none"> Incompatible mold lubricant 	<ul style="list-style-type: none"> Change mold lubricant
Warped parts	<ul style="list-style-type: none"> Mold too cold 	<ul style="list-style-type: none"> Preheat mold
	<ul style="list-style-type: none"> Clamp frames too cold 	<ul style="list-style-type: none"> Preheat clamp frames
	<ul style="list-style-type: none"> Removing part too soon 	<ul style="list-style-type: none"> Increase cooling cycle time
	<ul style="list-style-type: none"> Overheated part 	<ul style="list-style-type: none"> Use fans to help cool part Decrease mold temperature
	<ul style="list-style-type: none"> Uneven part cooling 	<ul style="list-style-type: none"> Add more coolant channels or tubing to mold Check for plugged water flow
	<ul style="list-style-type: none"> Poor material distribution 	<ul style="list-style-type: none"> For deep drawing, use pre-stretching or plug assist Check for uneven sheet heating
	<ul style="list-style-type: none"> Poor mold design 	<ul style="list-style-type: none"> Add vacuum holes Add moat to mold at trim line Check for plugged vacuum holes
Texture washout and gloss increase	<ul style="list-style-type: none"> Forming temperature too high 	<ul style="list-style-type: none"> Reduce heater temperature Decrease heater cycle time
	<ul style="list-style-type: none"> Improper heating technique 	<ul style="list-style-type: none"> Heat sheets from smooth side; keep texture side cool Pre-coat texture with strippable mask

TROUBLESHOOTING GUIDE

Description of Problem	Possible Causes	Possible Corrective Action
Non-uniform drape	<ul style="list-style-type: none"> • Uneven sheet heating 	<ul style="list-style-type: none"> • Check heater output and adjust • Use selective screening or shading to control heating • Check for cold air drafts in heating station
Incomplete forming of part, poor detail	<ul style="list-style-type: none"> • Sheet too cold 	<ul style="list-style-type: none"> • Increase heating time • Increase heater temperature • Increase watt density • Check for heating uniformity
	<ul style="list-style-type: none"> • Cold clamping frame 	<ul style="list-style-type: none"> • Preheat clamping frame
	<ul style="list-style-type: none"> • Insufficient vacuum 	<ul style="list-style-type: none"> • Check for clogged vacuum holes • Check for proper location of vacuum holes • Increase number of vacuum holes • Increase size of vacuum holes • Check vacuum pump • Check vacuum system for leaks
	<ul style="list-style-type: none"> • Vacuum not drawn fast enough 	<ul style="list-style-type: none"> • Where possible, use vacuum slots instead of holes • Increase size of vacuum holes • Increase vacuum surge and/or pump capacity • Increase size of vacuum line and valves; avoid bends and tee-elbow connections
	<ul style="list-style-type: none"> • Part draw ratio too large 	<ul style="list-style-type: none"> • Check for vacuum system for leaks
	<ul style="list-style-type: none"> • Insufficient pressure 	<ul style="list-style-type: none"> • Increase vacuum capacity • Add plug, pressure, or frame assist • Increase air pressure on side of part opposite mold surface, if mold can withstand this force • Use frame assist • Use plug, silicone, slab rubber, or other pressure assist • Increase pump capacity
Scorched sheet	<ul style="list-style-type: none"> • Top or bottom surface too hot 	<ul style="list-style-type: none"> • Decrease heating cycle time • Decrease heater temperature

TROUBLESHOOTING GUIDE

Description of Problem	Possible Causes	Possible Corrective Action	
Poor surface finish	<ul style="list-style-type: none"> • Mold surface too rough 	<ul style="list-style-type: none"> • Draw-polish mold or use mold material better suited to mold service requirements 	
	<ul style="list-style-type: none"> • Mold mark-off 	<ul style="list-style-type: none"> • Use powdered mold lubricant sparingly 	
	<ul style="list-style-type: none"> • Draft angle too shallow 	<ul style="list-style-type: none"> • Increase draft angle 	
	<ul style="list-style-type: none"> • Air entrapment over smooth mold surface 	<ul style="list-style-type: none"> • Grit-blast mold surface • Add vacuum holes in affected area 	
	<ul style="list-style-type: none"> • Insufficient vacuum 	<ul style="list-style-type: none"> • Add vacuum holes • Check for proper location of vacuum holes • Check vacuum system for leaks • Check for plugged vacuum holes 	
	<ul style="list-style-type: none"> • Mold too hot 	<ul style="list-style-type: none"> • Decrease mold temperature 	
	<ul style="list-style-type: none"> • Mold too cold 	<ul style="list-style-type: none"> • Increase mold temperature 	
	<ul style="list-style-type: none"> • Dirty sheet 	<ul style="list-style-type: none"> • Clean sheet with deionizing air gun 	
	<ul style="list-style-type: none"> • Dirty mold 	<ul style="list-style-type: none"> • Clean mold with deionizing air gun 	
	<ul style="list-style-type: none"> • Dust in atmosphere 	<ul style="list-style-type: none"> • Clean thermoforming area • Isolate thermoforming area and filter air 	
	<ul style="list-style-type: none"> • Scratched sheet 	<ul style="list-style-type: none"> • Polish sheet 	
	Loss of color	<ul style="list-style-type: none"> • Overdrawn sheet (Part too thin) 	<ul style="list-style-type: none"> • Increase sheet gauge • Increase sheet temperature • Use pre-draw • Use plug assist for deep-draw parts

TROUBLESHOOTING GUIDE

Description of Problem	Possible Causes	Possible Corrective Action
Chill marks or mark-off	<ul style="list-style-type: none"> • Mold temperature too low; stretching stops when sheet meets cold mold or plug 	<ul style="list-style-type: none"> • Increase mold temperature
	<ul style="list-style-type: none"> • Insufficient draft angle and radii 	<ul style="list-style-type: none"> • Increase draft angles and mold radii
	<ul style="list-style-type: none"> • Plug temperature too low 	<ul style="list-style-type: none"> • Increase plug temperature • Use wood plug assist • Cover plug with cotton flannel or felt
	<ul style="list-style-type: none"> • Sheet too hot 	<ul style="list-style-type: none"> • Reduce heater temperature • Heat more slowly • Use fans to reduce the surface of hot sheet slightly before forming
Nipples on mold side of formed part	<ul style="list-style-type: none"> • Vacuum holes too large 	<ul style="list-style-type: none"> • Decrease hole size
	<ul style="list-style-type: none"> • Dust on mold or sheet 	<ul style="list-style-type: none"> • Clean mold and sheet with deionizing air gun
	<ul style="list-style-type: none"> • Mold too cold 	<ul style="list-style-type: none"> • Increase mold temperature
	<ul style="list-style-type: none"> • Mold surface too smooth 	<ul style="list-style-type: none"> • Draw-sand mold surface with medium-grit paper
	<ul style="list-style-type: none"> • Vacuum rate too high 	<ul style="list-style-type: none"> • Place small orifice over main vacuum hole
	<ul style="list-style-type: none"> • Sheet too hot 	<ul style="list-style-type: none"> • Decrease heating cycle time • Decrease heater temperature
Webbing, bridging, or wrinkling	<ul style="list-style-type: none"> • Sheet too hot in center 	<ul style="list-style-type: none"> • Screen center of sheet, allowing edges to heat first; use taller vacuum box to provide more pull in area • Decrease heating cycle time • Decrease heater temperature
	<ul style="list-style-type: none"> • Sheet too cold in webbing area 	<ul style="list-style-type: none"> • Use pattern heating • Increase billow height
	<ul style="list-style-type: none"> • Mold too cold 	<ul style="list-style-type: none"> • Increase mold temperature
	<ul style="list-style-type: none"> • Vacuum rate too fast 	<ul style="list-style-type: none"> • Slow down vacuum rate • Use smaller vacuum holes • Restrict main vacuum line
	<ul style="list-style-type: none"> • Insufficient vacuum 	<ul style="list-style-type: none"> • Check vacuum system for leaks • Increase number of vacuum holes or slots • Check for clogged vacuum holes • Check for proper location of vacuum holes • Increase size of vacuum holes

TROUBLESHOOTING GUIDE

Description of Problem	Possible Causes	Possible Corrective Action
Webbing, bridging, or wrinkling – Cont.	<ul style="list-style-type: none"> • Draw ratio too great in area of mold, or poor mold design or layout 	<ul style="list-style-type: none"> • Redesign mold • Use plug or ring mechanical assist • Use female mold instead of male mold • Add take-up blocks to pull out wrinkles • Increase draft and radii where possible • Increase space between multiple articles • Speed up assist and/or mold travel
	<ul style="list-style-type: none"> • Blanks too large for mold 	<ul style="list-style-type: none"> • Redesign grid, plug, or ring assists • Leave minimum of material around mold
	<ul style="list-style-type: none"> • Uneven cooling due to slow drape speed 	<ul style="list-style-type: none"> • Drape at higher speed
Insufficient draw-down	<ul style="list-style-type: none"> • Improper sheet heating 	<ul style="list-style-type: none"> • Increase heating time and temperature
	<ul style="list-style-type: none"> • Insufficient vacuum 	<ul style="list-style-type: none"> • Check vacuum system for leaks
Poor wall thickness distribution and excessive thinning in some areas	<ul style="list-style-type: none"> • Uneven heating 	<ul style="list-style-type: none"> • Check uniformity of heater output • Use screening or shading to control heating • Check for drafts or air current in heating station
	<ul style="list-style-type: none"> • Improper forming technique 	<ul style="list-style-type: none"> • Use billow or snap-back forming method • Reduce time delay between pre-stretch and mold drawing • Control height
	<ul style="list-style-type: none"> • Excessive sag 	<ul style="list-style-type: none"> • Reduce sheet temperature • Use pattern heating
	<ul style="list-style-type: none"> • Cold mold 	<ul style="list-style-type: none"> • Increase mold temperature • Check for uniform mold heating • Check temperature control system for scale or plugging
	<ul style="list-style-type: none"> • Sheet pulls from rails 	<ul style="list-style-type: none"> • Air-cool rails prior to heating • Move rails in to grasp more sheet • Use drag bands at rail edge
	<ul style="list-style-type: none"> • Sheet slips from frame 	<ul style="list-style-type: none"> • Adjust frame alignment • Increase frame clamp pressure • If retainer springs are used, change to high-temper springs • Pre-heat frames prior to inserting sheet • Check heaters around clamp area for proper operation • Screen or shade center of sheet to allow more heat at perimeter

TROUBLESHOOTING GUIDE

Description of Problem	Possible Causes	Possible Corrective Action
Shiny streaks on part	<ul style="list-style-type: none"> • Sheet too hot in spots 	<ul style="list-style-type: none"> • Lower heater temperature in overheated area • Use screening or shading to control heating • Decrease heating cycle time • Increase distance between heater and sheet
Excessive shrinkage or distortion of part after removing from mold	<ul style="list-style-type: none"> • Part not adequately cooled 	<ul style="list-style-type: none"> • Increase cooling cycle time • Use cooling fixtures • Increase capacity of cooling system • Use fan or vapor spray mist to cool part faster on mold
	<ul style="list-style-type: none"> • Mold too hot 	<ul style="list-style-type: none"> • Reduce mold temperature • Increase mold coolant flow rate
Corners too thin in deep draw	<ul style="list-style-type: none"> • Uncontrolled material distribution 	<ul style="list-style-type: none"> • Consider other techniques such as billow-up, plug assist, etc.
	<ul style="list-style-type: none"> • Sheet too thin 	<ul style="list-style-type: none"> • Use heavier-gauge sheet
	<ul style="list-style-type: none"> • Sheet temperature too high at corners 	<ul style="list-style-type: none"> • Use screening or shading to control heating pattern
	<ul style="list-style-type: none"> • Mold temperature not uniform 	<ul style="list-style-type: none"> • Adjust temperature control system for uniformity • Check operation of mold heating system
	<ul style="list-style-type: none"> • Drape speed too fast 	<ul style="list-style-type: none"> • Reduce drape speed

TROUBLESHOOTING GUIDE

Description of Problem	Possible Causes	Possible Corrective Action
Difficult part removal	• Part or female mold temperature too hot	• Increase cooling cycle time • Decrease mold temperature
	• Male mold too cold, part sticking	• Increase mold temperature
	• Male mold too hot, causing part distortion	• Decrease mold temperature
	• Insufficient mold draft	• Increase taper/draft • Use female mold • Remove part from mold as soon as possible
	• Ejection pressure too low	• Add air holes • Increase injection pressure • Use powdered mold release
	• Mold undercuts	• Use stripping frame • Increase air-eject air pressure • Remove part from mold as soon as possible
	• Wood Mold	• Spray mold surface with a compatible mold release agent
	• Rough mold surface	• Polish corners or entire mold surface • Use mold-release agent • Use PTFE spray
Loss of vacuum seal	• Cold clamp frames	• Preheat clamp frames
	• Improper spacing between clamp frames and vacuum box	• Adjust space between clamps and vacuum box to between 0.50 and 0.750 in. (13 and 19mm)
Sheet sticking to plug	• Plug temperature too hot	• Decrease plug temperature • Use mold release agent on plug • Apply a PTFE coating • Cover plug with felt cloth or cotton flannel
	• Wood plug assist	• Cover plug with felt cloth or cotton flannel • Use mold release agent on plug • Apply a permanent PTFE coating to surface of plug
Tearing of sheet during forming	• Mold design	• Increase corner radius
	• Sheet too hot	• Decrease heating cycle time • Decrease heater temperature • Check sheet for uniform heating • Preheat sheet
	• Sheet too cold (usually thinner gauges)	• Increase heating cycle time • Increase heater temperature • Check sheet for uniform heating • Preheat sheet

TROUBLESHOOTING GUIDE

Description of Problem	Possible Causes	Possible Corrective Action
Tearing of sheet during forming - Cont.	<ul style="list-style-type: none"> Poor material distribution 	<ul style="list-style-type: none"> Check sheet for variations in gauge Check sheet for uneven heating
	<ul style="list-style-type: none"> Pre-stretch too large 	<ul style="list-style-type: none"> Reduce billow blowing time Reduce billow temperature
Cracking of part during service	<ul style="list-style-type: none"> Stress concentration 	<ul style="list-style-type: none"> Increase fillets Increase sheet temperature Be sure part is completely formed before removing from mold Use proper forming temperature and cooling rate for deep-draw parts Increase mold temperature
	<ul style="list-style-type: none"> Poor part or mold design 	<ul style="list-style-type: none"> Re-evaluate design
	<ul style="list-style-type: none"> Sheet gauge too thin for draw 	<ul style="list-style-type: none"> Increase sheet gauge
	<ul style="list-style-type: none"> Uneven sheet temperature 	<ul style="list-style-type: none"> Use screening or shading to control heating pattern
	Poor embossing detail	<ul style="list-style-type: none"> Embossing depth too shallow
<ul style="list-style-type: none"> Drawing not uniform 		<ul style="list-style-type: none"> Use screening or shading to control heating pattern Use plug assist and/or billow to pre-stretch sheet
Excessive sheet sag	<ul style="list-style-type: none"> Sheet too hot 	<ul style="list-style-type: none"> Decrease heating cycle time Decrease heater temperature
	<ul style="list-style-type: none"> Sheet area too large 	<ul style="list-style-type: none"> Use screening or shading to control heating, particularly in the center of the sheet.
Varying sag levels among sheets	<ul style="list-style-type: none"> Sheet-to-sheet temperature variation 	<ul style="list-style-type: none"> Check for cold air drafts in heating station
Non-uniform billow	<ul style="list-style-type: none"> Uncontrolled sheet heating 	<ul style="list-style-type: none"> Check heaters for proper operation Use screening or shading to control heating Check for cold air drafts in heating station
	<ul style="list-style-type: none"> Non-uniform die pressure within billow 	<ul style="list-style-type: none"> Check air pressure system for leaks Check seal between sheet and billow box Redirect incoming air to billow box



**BRAKE BENDING,
COLD FORMING,
ANNEALING**

BRAKE BENDING

Brake bending

TUFFAK polycarbonate sheet up to 0.177" (4.5mm) thick can be brake bent up to 90° angles. For gauges thicker than 0.177" (4.5mm), strip heat bending is recommended to prevent potential cracks or breakage. Strip heat bending should also be used for all flame-resistant sheet grades.

TECH TIPS:

- Perform the bending operation quickly
- To attain the desired angle, some degree of over-bend is required
- Do not brake bend flame retardant grades due to possibility of cracking
- For best results with gauges greater than 0.177" (4.5mm), use two-side heating, or turn the part frequently when using a one-side heater. This helps with even heat penetration, preventing moisture bubbling.
- Additionally, for gauges greater than 0.177" (4.5mm), back route or V-groove with a 1/16-inch (1.52mm) radius to heat cross section. Again, this will help avoid moisture bubbling, while still creating a sharp angle.
- It is recommended to sand and polish the edges of the sheet before bending. The small cracks of a rough edge can cause cracking of the sheet during bending.
- Blade radius should be 0.158"-0.236" (4-6mm)
- Hard coated sheet should not be bent as the coating will microcrack.

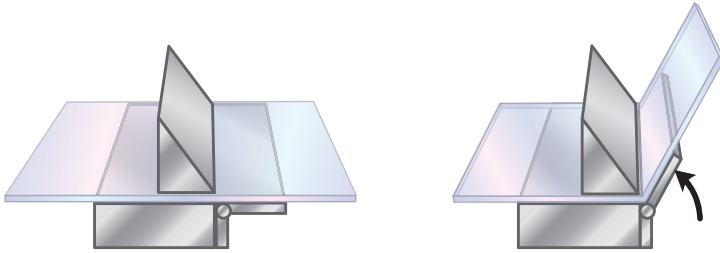

Annealing

Batch oven method

Annealing is a way of relieving internal stresses in thermoplastic parts caused by thermoforming or fabrication. The polycarbonate sheet is thermal conditioned at an elevated temperature over a specified time period and then cooled slowly. Through annealing, potential dimensional instability of a part, such as warp, is also reduced.

While annealing is effective for reducing stresses, it is time-consuming and may not be economical or practical for all situations. Also, extended heat histories can affect the physical properties of plastics. If you have questions or concerns regarding annealing, contact your Plaskolite representative, or the Technical Service Group.

COLD FORMING

Cold forming

TUFFAK sheet may be cold-formed, bent into place without heating, to a radius based on the sheet thickness. As a guideline, the minimum cold forming radius is equal to 100 times the thickness: ($R = T \times 100$).

Cold forming radius guide - inch

Sheet thickness	Minimum radius
0.118" (3mm)	12" (30cm)
0.177" (4.5mm)	18" (46cm)
0.236" (6mm)	24" (61cm)
0.370" (9.4mm)	37" (94cm)

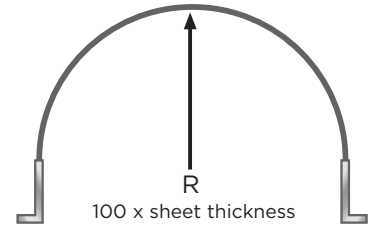

TUFFAK cold forming product guide

Cold formable	Not cold formable
GP	15
DX-NR	AR
FC	HYGARD®
FI	NR-C
LF	CA-AR
LD	DG
Lumen XT	
NR	
OP	
SL	
SK	
UV	
CA	
CA-UV	
WG	
LS	

Annealing procedure:

1. Prior to heating, support or fixture the part to the desired geometry using low thermal conductivity framing (e.g., wood)
2. Slowly heat oven, fixture and part at the same time to 250°F (121°C)
3. Hold at 250°F (121°C) for 15 minutes per 0.125" (3.1mm) sheet thickness
4. Turn off heater, blower remains on, starting the cool-down cycle
5. Remove part from oven, remove the part from the fixture



BONDING APPLICATIONS

BONDING APPLICATIONS

A wide range of adhesives is available in the market. Polyurethane, epoxy, and silicone adhesives may be used however, the choice of the right type of adhesive depends on the application and should be done carefully. Adhesion technology is a very technical field by its own. Apart from properties such as flexibility, mechanical strength, durability (indoor-outdoor) of the bond, the compatibility of the adhesive to TUFFAK polycarbonate must be assessed especially for solvent bonding. Any substance that comes with contact with polycarbonate should be checked for compatibility. Even if the supplier confirms that the material is suitable for polycarbonate, apply first to a hidden area to see if there are any effects. However, this will cover for short-time effects only. To assess long-term effects of substances on polycarbonate, laboratory testing is strongly suggested.

Solvent bonding

Solvent bonding joins one plastic to itself or another type of plastic that dissolves in the same solvent. Typically, this process involves treating the bonding area with the **minimum** amount of solvent needed to soften the surfaces and then clamping the parts together until they bond.

Methylene chloride or ethylene dichloride bonds TUFFAK sheet to itself. Methylene chloride's fast evaporation rate helps to prevent solvent vapor entrapment for simple assemblies. For complex assemblies that require more curing time, use ethylene dichloride. A 60/40 mixture of methylene chloride and ethylene dichloride will allow for longer a time to assemble parts than pure methylene chloride.

Expect brittleness and reduced impact strength at the bonded joints.

**Note: Wear proper protective equipment when working with chemicals.
Adequate ventilation is essential.**

Review Safety Data Sheet from product manufacturer and control exposure according to OSHA guidelines.

Bonding procedure

1. For optimum bonding, confirm the parts mate flush. This helps to ensure uniform pressure distribution across the entire bond area.
2. Clean joint surfaces with isopropyl alcohol.
3. Use fresh solvent.
4. For best results, avoid using excessive solvent - it causes bubbling and "squeeze-out," which decreases bond strength.
5. Apply a thin bead of solvent using a needle applicator; the capillary action will pull the solvent into the joint interface.
6. For large parts, it may be easier to use a shallow pan containing enough solvent to cover the edge of the bonding part.
7. Dip part into pan, wetting its edge.
8. Transfer onto mating part.
9. Apply pressure to the mating parts.
10. Hold fixture for a minimum of 60 seconds.
11. The bonded part is now safe to handle.

BONDING APPLICATIONS

Avoid whitening of bond

- » Use fresh solvent whenever possible. Once a container is opened, the solvent can absorb moisture from the air over time. Wet solvent can cause a cloudy bond.
- » Fabricate in a climate controlled area with low relative humidity.
- » Add 10% glacial acetic acid to a container of previously opened solvent to help reduce whitening.
- » Add 5-10% polycarbonate shavings to the solvent to help slow cure time and reduce whitening.

Adhesive bonding

Adhesive bonding systems are among the most robust for joining plastic parts to parts made of the same plastic, different plastics or non-plastic materials. Generally, adhesives produce more consistent and predictable results in joints requiring strength and durability than other joining methods.

Consider the following when selecting an adhesive bonding material:

- » Chemical compatibility with TUFFAK sheet
- » Flexibility or rigidity requirements
- » Load bearing force
- » Environmental condition and temperature requirements
- » Aesthetics

General characterizations of different adhesive systems:

- » In general, urethane and epoxy adhesives impart excellent bond strength.
- » UV-cured adhesives, attractive for curing in seconds, provide high bond strength.
- » Silicone adhesives have flexible, strong bonds.
- » Foamed adhesive tapes are known for strength and durable performance.
- » Hot melts provide quick set times where high bond strength is not required.
- » Use care in selecting adhesives, as some can be aggressive toward TUFFAK sheet.

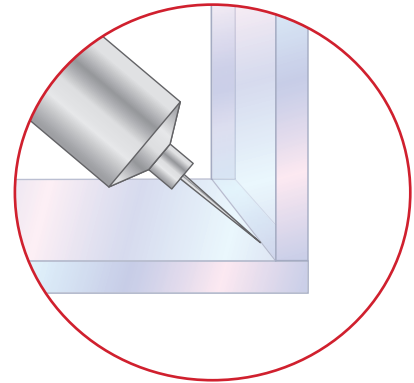

**Typical Butt-T
Joint Design**

The design of the adhesive joint has an influence on the final strength of the bond. Joints should be designed in a way that transform tensile or compressive stress to shear stress. The larger the bonding area, the stronger the bonding. Butt joints can form a weak bonding joint. Overlapping sheets or adding a strip of polycarbonate along the joint line improves the bonding strength of the joint.

TECH TIPS:

- » A fully cured joint requires 24-48 hours drying time
- » Always cure parts in a well-ventilated area; never in an enclosed space. Trapped methylene chloride vapors chemically attack polycarbonate, reducing its physical properties.
- » A 5-10% solution of polycarbonate shavings dissolved in methylene chloride helps to produce a smooth, filled joint and improves strength. For critical applications requiring more durability consider an adhesive product.

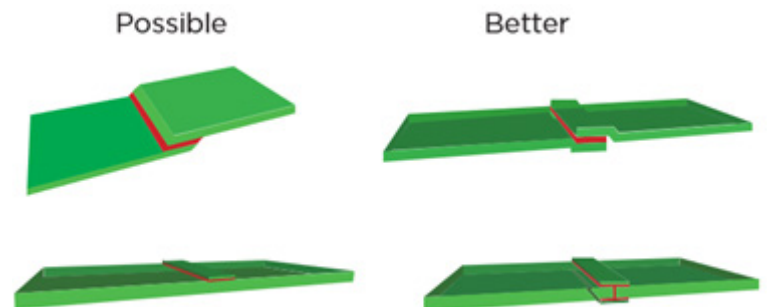

BONDING APPLICATIONS

Adhesion selection guide

Product	Description	Bond type
Methylene chloride	Solvent	High tensile strength, low impact resistance
Urethane	Polymer base	Structural bond, fatigue resistant, limited flexibility and UV resistance
Epoxy	Polymer; 1 and 2 component	Structural bond, heat and chemical resistant, limited flexibility, absorbs moisture
Silicone	Silicone	Flexible, strong bond, heat, chemical, environmentally resistant
Adhesive tape	Acrylic adhesive foam-backed, films	Flexible, structural bond, for non-aesthetic uses
Hot melts	Polymer	Fast set, versatile, range of bond strengths

Selected product web links

Solvent, hardware store, chemical suppliers

SOLVENT CEMENT:

http://es.ipscorp.com/pdf/assembly/AssemblyAdhesive_Product_Selection%20Guide_Jan08.pdf

URETHANE: <http://es.ipscorp.com/assembly/polycarbonate;>

EPOXY: <http://www.masterbond.com/lp/performance-properties-and-common-applications>

SILICONE: <http://www.tremcosealants.com/products/proglaze-ssg.aspx>

ADHESIVE TAPE: http://solutions.3m.com/wps/portal/3M/en_US/Adhesives/Tapes/Brands/3M-VHB-Tape/

HOT MELT: <https://www.bostik.com/us/Bostik-products/thermogrip-h2315-02-hot-melt-pressure-sensitive-adhesive>

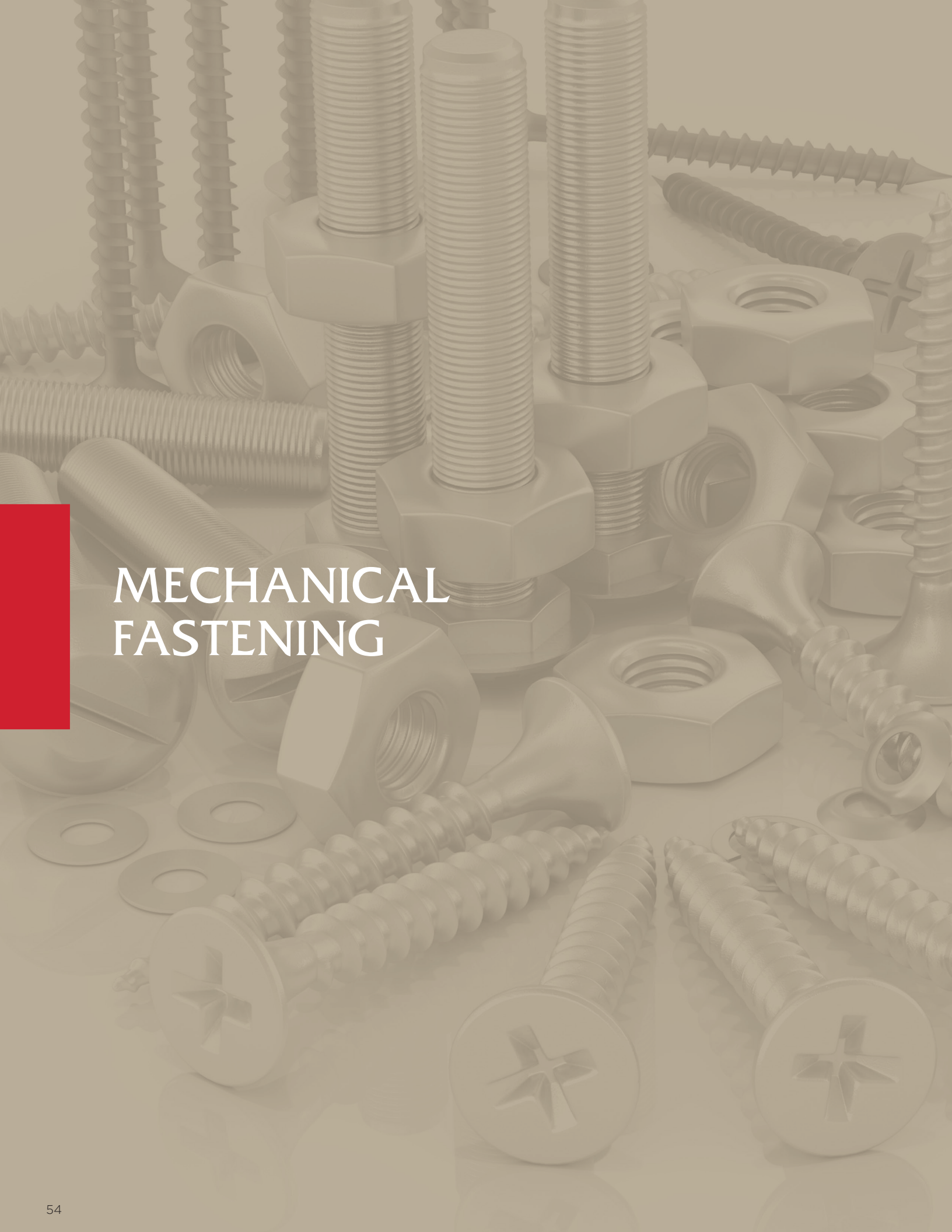

MECHANICAL FASTENING

MECHANICAL FASTENING

Mechanical fasteners

Due to their low cost and reliability, screws, bolts, and rivets are common joining methods. Common practices and selection criteria are discussed within this section.

Common head styles of screws and bolts

Pay special attention to the fastener's head. Use bolt and screw heads that have a flat underside, called "pan" or "round" head. This bolt design imparts lower compressive stresses on the material. Conical heads, called flat or oval heads, produce undesirable tensile and hoop stresses and should be avoided.

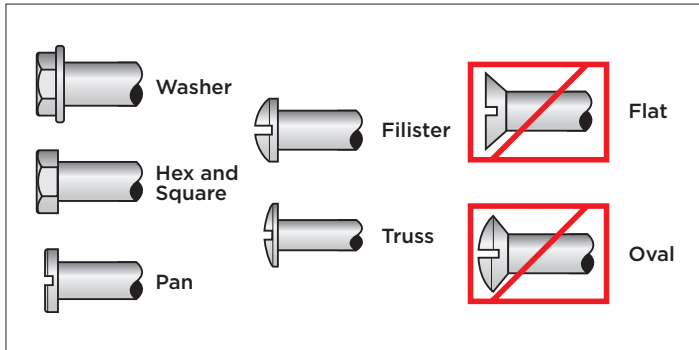

Fastening with self-tapping screws

Use thread-cutting screws, which cut away material from a pre-drilled hole to form a mating thread and result in better long-term performance. Note the radial and hoop stresses imparted to the part by thread-cutting screws are lower after installation vs. thread-forming screws. Typically, thread-cutting screws are classified as ANSI BT (Type 25), ANSI T (Type 23). Thread-cutting screws may not be appropriate in all applications and environments. Cracks around the screw hole may form under conditions where the polycarbonate expands and contracts due to temperature variations.

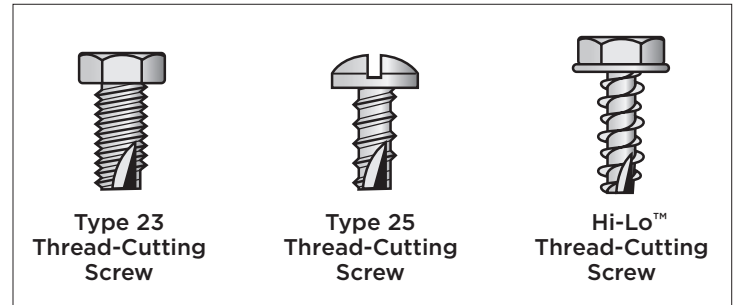

Hi-Lo is a trademark of ITW Shakeproof

Fastening with bolts, nuts, and washers

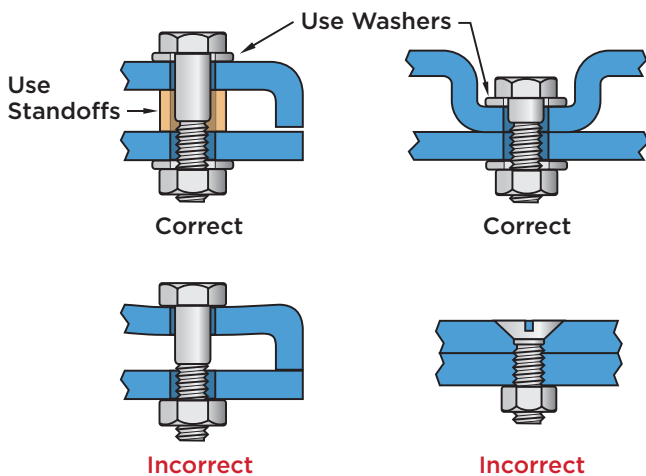

Fastening with rivets

Rivets offer a low-cost and simple hardware solution for static parts. Aluminum rivets are preferred over harder materials. Select rivets with large flat heads and three times the shank diameter. Use of washers on the flared end are helpful in distributing loads, but be careful not to over-tighten as it can result in compressive stress and damage to the plastic.

Four standard rivet heads

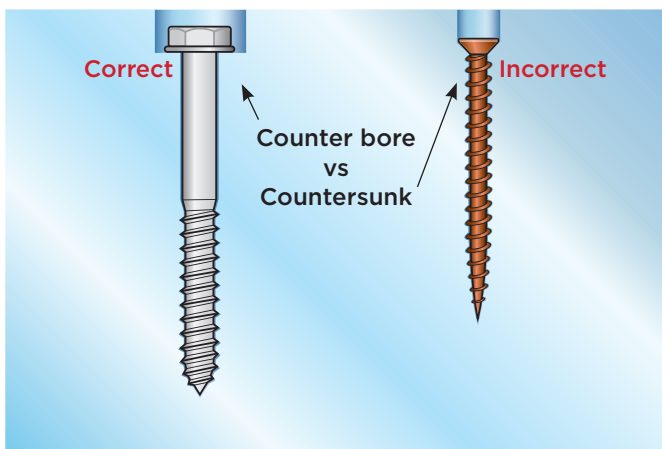
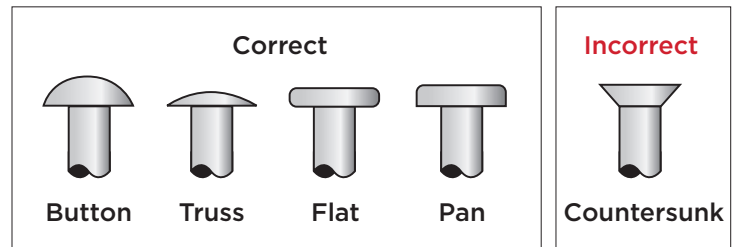

Use flat aluminum or hard plastic washers under nuts and fastener heads to evenly distribute the applied force. Their ability to resist over-compression helps to prevent localized stressing of the joining part. Ensure there is sufficient distance between the edge of the fastener's hole and the part's edge: at minimum, two-times the diameter, and twice the part's thickness. Note: Slotted holes require more edge clearance.

TECH TIP:

Avoid thread locker products. They are generally incompatible with TUFFAK polycarbonate sheet, causing cracking and crazing.

MECHANICAL FASTENING

Joining dissimilar materials

For assemblies constructed of a combination of TUFFAK sheet and metal (two dissimilar materials), it is important to design for thermal movement behavior. When heated, the plastic may buckle, due to its higher thermal expansion rate. Conversely, when cooled, the greater thermal shrinkage of plastic will cause strain-induced stress and may exceed the plastic's working limit. This could lead to part failure.

The figure to the right shows a plastic part fastened to a metal component. As the ambient temperature rises, the plastic will expand more than the metal because the plastic's coefficient of linear thermal expansion is four times higher.

For applications where wide temperature variations exist, use slotted screw holes in the plastic part. When joining plastic and metal parts, do not tighten fasteners to the point where joint friction and compressive loads prevent relative movement. If the fasteners are too tight it negates the effect of the slotted holes.

Factors to consider when joining plastic and metal parts:

- » The size of the parts to be joined
- » The magnitude of the temperature range
- » The relative thermal expansion coefficients of the materials used in the part

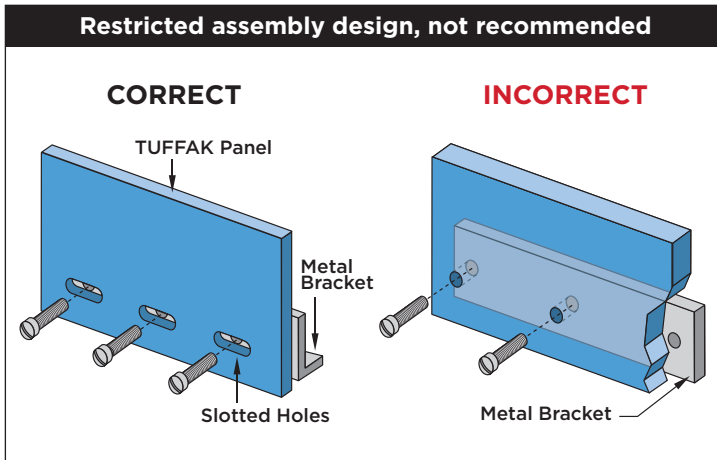
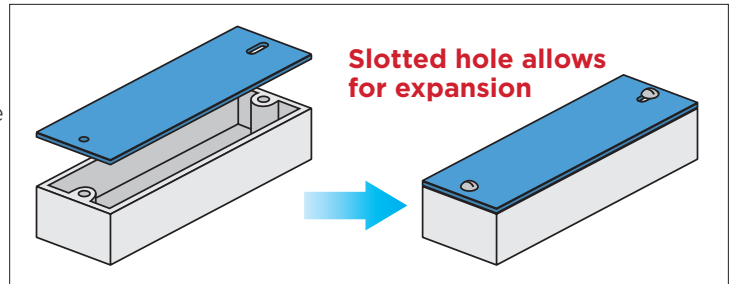
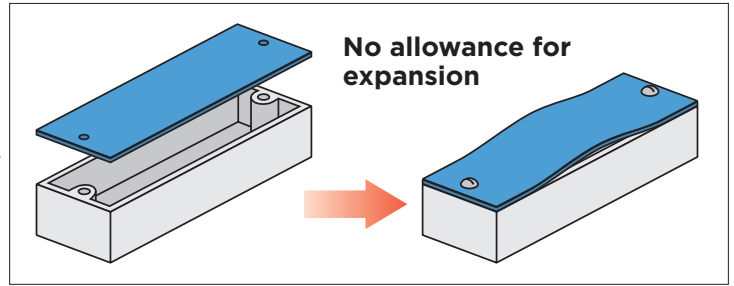

Material	CTLE (10 ⁵ in/in/°F), cm/cm-°C
TUFFAK	3.8, 6.8
Aluminum	1.3, 2.3

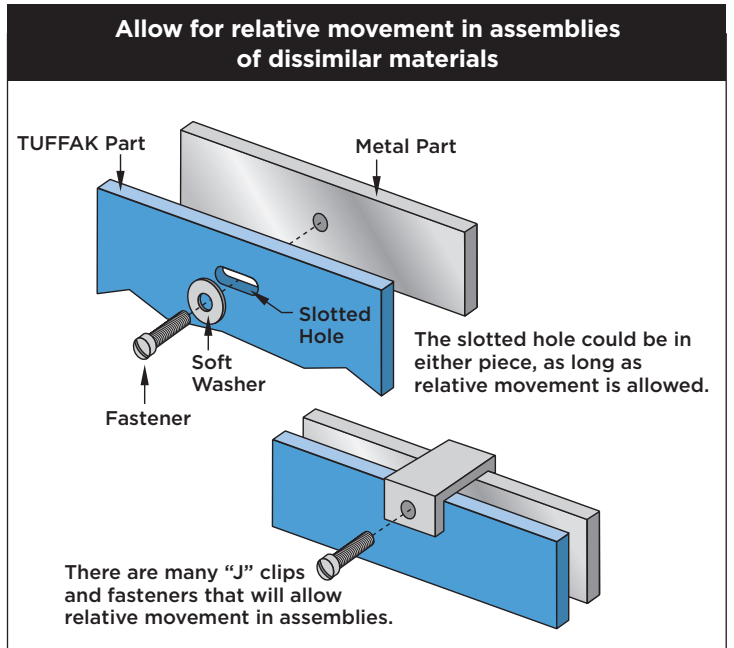

Coefficient of Linear Thermal Expansion (CLTE) values for materials

Example 1: Calculate the change in length for a 96 inch (244cm) part that is constructed at 70° F, (21°C) but will see operating temperatures up to 120° F (49°C)

$$L = (\text{plastic CLTE} - \text{metal CLTE}) * \text{temperature change} * \text{length of part} \quad (0.000038 - 0.000013) * 50 * 96 \quad L = 0.120 \text{ inches} \quad (3.0\text{mm})$$

Therefore, the design has to accommodate a growth of 0.12 inches (3.0mm).

Example 2: How much shrinkage will the same part see at -20° F (-29°C)

$$L = (\text{plastic CLTE} - \text{metal CLTE}) * \text{temperature change} * \text{length of part} \quad (0.000038 - 0.000013) * 90 * 96 \quad L = 0.216 \text{ inches} \quad (5.5\text{mm})$$

Therefore, the design has to accommodate a contraction of 0.216 inches. (5.5mm)

MECHANICAL FASTENING

Ultrasonic welding

An ultrasonic welder has two primary parts: a horn and a nest. The horn typically presses down on the upper plastic part (of the two to be welded), clamping the two parts together. The nest supports the bottom plastic part to prevent it from moving. The horn is vibrated ultrasonically for a preset time. Friction from mechanical vibrations cause localized heating, resulting in plastic melting at the interface of the two parts. Pressure is then maintained after the vibrations are stopped until the melted plastic cools. Once the plastic has solidified, the clamping pressure is retracted and the two joined parts can be removed from the nest fixture.

The most important feature for a clean, ultrasonically welded joint is for one of the parts (to be welded) be designed with a triangular-shaped energy director. This minimizes the initial contact between parts. During welding, the ultrasonic energy is concentrated at the director tip, melting it and ultimately, joining the interface with molten resin.

Design energy directors with an apex angle from 60 to 90°. Generally, the base width of the energy director should not be more than 20 to 25% of the wall thickness supporting it.

Troubleshooting

- » Clean the mating surfaces with isopropyl alcohol to remove dust, fingerprints, and grime prior to welding.
- » Check to see if the horn is making proper contact to the welding surface. Non-uniform horn contact produces non-uniform weld lines. Carbon paper is useful to confirm uniform contact.
- » Confirm sufficient energy is being supplied into the weld.
- » Increase pressure/clamping force on the parts being welded.
- » Increase the weld time.
- » Increase the amplitude to the horn. Consult equipment suppliers for recommended welding amplitude settings for polycarbonate.

For ultrasonic welding machines, the converter, booster, and a properly maintained weld horn are all key factors for delivering a welding amplitude that produces a repeatable and robust weld joint. Confirm that routine maintenance, daily checks and calibration programs are in place. Set and document minimum energy output for the unit that ensures a reproducible welding joint.

TUFFAK polycarbonate can be welded by different methods: ultrasonic, spin welding, and radio frequency. Welding is most useful when attaching polycarbonate to itself. For assembling TUFFAK to other materials, screwing or bonding may be a better option. Different welding methods generate heat energy that soften the edges and the weld the joint. This process leaves great stress in the material, which should be relieved later by annealing. This method results in weak joints, 10% to 40% of the original strength. Welding techniques are considered generally to be irreversible and are used in applications where disassembling is not required.

For optimum welding:

- » The horn, fixture and parts must be aligned properly
- » The stationary part should fit snugly in the nest or fixture
- » The height of the energy director should be approximately 0.020 inch (0.51mm)
- » Join parts made of the same resin

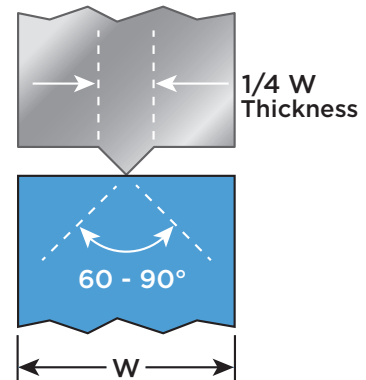

For more information on ultrasonic joining techniques contact:

Dukane Corp. http://www.dukane.com/us/PPL_upa.htm

Forward Technology Industries, Inc. <http://www.forwardtech.com/plastic-assembly>

Herrmann Ultrasonics, Inc. <http://www.herrmannultrasonics.com/en-us>

Ultra Sonic Seal Co. http://www.ultrasonicseal.com/upa/upa_tooling.html



TEKNOLOGI UTAMA LY2 P

FINISHING

FINISHING

The aesthetics or functionality of TUFFAK sheet can be enhanced through finishing or surface-decorating processes. Painting and screen-printing are typical decorating methods for enhancing a part's visual appeal. Metallizing is an example of a process that adds functionality, such as electromagnetic shielding. Before decorating with any material, contact the manufacturer to confirm its suitability for use, and compatibility with polycarbonate.

PRODUCT GUIDE: DECORATION METHOD

TUFFAK Products	Digital Print	Screen Print	Paint	Vinyl	Hot Decorating
AR1 ⁴	*	*	*	*	*
GP	*	*	*	*	*
DX-NR ¹	*	*	-	*	*
FC ²	-	-	-	*	-
FI	*	*	*	*	*
LF	*	*	*	*	*
LD	*	*	*	*	*
Lumen XT ¹	*	*	*	-	*
NR ¹	*	*	*	*	*
NR-C ⁴	*	*	*	*	*
OP	*	*	*	*	*
SL	*	*	*	*	*
SK ³	-	-	*	-	-
CA	*	*	*	*	*
CA-UV	*	*	*	*	*
CA-AR ⁴	*	*	*	*	*

1. Textured surface may interfere with decoration media, requires testing/verification

2. Hard coat surface interferes with adhesion, requires testing/verification

3. Painting prismatic surface will interfere with optical properties, requires testing/verification

4. AR1, NR-C and CA-AR decorate the non-coated side of the sheet

Screen printing

TUFFAK sheet can be printed with standard silk screening equipment. Note that screen mesh affects both the amount of ink that is deposited, as well as the resolution of the printed image.

As with all thermoplastics, TUFFAK sheet must be clean and free from surface contaminants prior to screening. Many screen printers use a 50:50 washing solution of water: isopropyl alcohol to clean the surface prior to printing. Be sure to use soft, nonabrasive cloths when cleaning to avoid scratching. Antistatic or ionized air guns also provide a good method for removing lint and dust, as well as static.

After printing, keep sheets separate on a drying rack until ink is dry. DO NOT pack sheets for shipment until inks are completely dry.

Digital printing

UV cured inks are used in digital printing due to their quick cure times. Historically, a UV Mercury arc lamp has been used as the light source, but newer UV LED curing lamps are now preferred. These bulbs use less electricity, produce less heat, last much longer and do not require a warm-up period. It's important to note however, that the market has reported intermittent adhesion issues when printing on plastic substrates when curing with UV LED systems. Pretreating the plastic substrate with corona discharge, flame, UV light, solvent wipes, or adhesion promoters has proven successful in overcoming adhesion issues.

For advice on UV LED cure ink applications, contact the Technical Service Group at 800.628.5084 or the Resources tab at Plaskolite.com for detail information.

Painting

Many commercial paints are available for TUFFAK sheet. Be sure to use only paints that have been tested by the supplier to be compatible with polycarbonate. As with screen printing, it is important the surface of the TUFFAK sheet be clean and free from surface residuals prior to painting. Many painters use a pre-rinse of 50:50 (water : isopropyl alcohol) to clean the surface. Be sure to dry thoroughly prior to painting. Use a soft, nonabrasive cloth or sponge to avoid scratching.

Conventional spray, spray masked, roller coat and brush are common application methods. Beware of paints containing solvents.

Vinyl decorating

Application of colored vinyl film is a common decoration technique for TUFFAK sheet. Follow the vinyl film manufacturer's directions for product use. Flash drying TUFFAK sheet for at least one hour at 250°F (121°C) prior to the film application has been useful in helping to prevent bubbling or blistering of the film over time as does adding an adhesion promoter to improve bonding surface.

FINISHING

Hot stamping

TUFFAK sheet is easily decorated with a single-color image by hot stamping, a process widely used for its convenience, versatility and performance. A heated die fuses the impression made by the stamp to transfer color from the foil carrier to the substrate. The temperature, pressure and dwell time are adjusted based on the type of foil and substrate. Contact equipment and foil manufacturers about processing conditions and products for polycarbonate.

Heat transfer

Heat transfer decorating also uses a combination of heat, pressure, and dwell time to apply preprinted graphics onto a part. Unlike hot stamping, the graphics are preprinted images that can be complex and multicolored. The major advantage of heat transfer decorating over printing or painting is that it is a dry process, making it more environmentally friendly. There are no strong odors associated with the process from volatile chemicals.

Printing and painting hard coated sheet products

Adhesion of ink and paint to the abrasion resistant coated surface is unreliable and not recommended on TUFFAK 15, TUFFAK AR, TUFFAK NR-C and TUFFAK FC. TUFFAK ARI is a one-side hard coated sheet that can be printed on the side opposite of the coating, thus allowing for decoration in combination with the weatherable abrasion resistant coating.

Solvent polishing

To improve the look of saw-cut edges, begin by sanding the edges smooth. For smoother, glossy edges, consider solvent polishing with methylene dichloride. To prevent humidity blush after drying, it may be necessary to add a small amount of glacial acetic acid. Keep in mind that polishing cannot be expected to totally eliminate sand marks from the sheet edge. Solvent polishing is not recommended on laminated products and should only be used on monolithic polycarbonate sheet.

Note: Use extreme caution when working with solvents. Adequate ventilation is essential. Control exposure levels according to OSHA guidelines. Obtain Safety Data Sheets from the solvent manufacturer.

Sanding

The edges of TUFFAK sheet can be sanded using both wet and dry techniques. Of the two, wet sanding produces a smoother finish and is less likely to gum the sandpaper. In both instances, the part will require further finishing such as solvent polishing in order to yield a high gloss appearance.

TUFFAK sheet can also be buffed using a 2-wheel system. The first wheel uses a buffing compound to remove shallow scratches. The second buffing wheel is used for restoring the gloss.

Jointing-planing

A standard woodworking jointer-planer can be used to finish TUFFAK sheet edges. Blades must be carbide or high-speed steel. Avoid removing too much material in each pass, 1/64" (0.4mm) or less normally yields the cleanest edge. Attempting to remove too much material in a single pass results in a rough edge or cracking of the sheet.

If smoother edges are required, wet sanding with fine grit sandpaper is recommended.

TECH TIPS

Ghosting Problems When Printing

When TUFFAK sheets are intended for printing applications, it is recommended to order the sheets with plain PE protective film (i.e. without any printed logos). Printed logos in the PE films may cause "ghosting", i.e. a "watermark-like" defect on the printed sheet. If a TUFFAK logo is required in the PE masked protective sheet, printing should be performed on the reverse side of the sheet.

SOURCES

INK

ASPA: www.screenprinting-aspa.com/inks-for-screen-printing.html

NAPIM: www.napim.org/printing-inks

PNEAC: www.pneac.org

SignIndustry.com: www.signindustry.com/screen/

DIGITAL PRINTING

EFI: <https://customer.efi.com/support/ccplIndex>

Radtech: www.radtech.org

ScreenWeb: www.screenweb.com/bg

SGIA: www.sgia.org/printing-imaging/digital-printing-and-imaging

FOIL

FSEA: www.fsea.com

PAINT

ACA: <http://paintandcoatingsbuyersguide.com>

Akzo Nobel Coatings: www.akzonobel.com

Matthews Paints: www.ppg.com

Naz-Dar Corporation: www.nazdar.com

SignIndustry.com: www.signindustry.com/painted



GLAZING GUIDELINES

DAL GRAUER

SUBSTATION

GLAZING

TUFFAK polycarbonate sheet can be installed using wet (caulking type sealant) or dry (gasket type) glazing systems. TUFFAK sheet can be glazed as a single layer, as two layers for added thermal insulation or over-glazed for increased security to an existing window.

General recommendations

- » Match the metal framing's rating (typically heavy gauge aluminum or steel) to the application, such as high wind loads or force entry or ballistics requirements.
- » Engage all sheet edges in the frame
- » Ensure the rabbet depth is sufficient for edge engagement, as well as thermal expansion or contraction
- » Use gaskets, sealants, and tapes compatible with polycarbonate that have adequate elongation capability; contact the manufacturer of the product if unsure
- » Note that fastening with bolts through the glazing should only be used when unavoidable; the design needs to be reviewed to ensure thermal movement will not be restricted
- » Note that a sash intended for glass is unlikely to have enough rabbet depth, particularly for windows larger than 36 inches (91cm) in one dimension
- » Use dry glazing with EPDM or neoprene gaskets for large windows (greater than 24 inches, 61cm); sealants specifically designed with high elongation may also be a consideration
- » Peel back the masking only around the perimeter of the sheet prior to installation to protect from damage. Remove the remaining masking once the installation is complete. Do not leave the masking on the sheet for an extended period.
- » Use isopropyl alcohol or VM&P naphtha and a soft cloth for cleaning during installation
- » Refer to the TUFFAK sheet cleaning guideline for recommended practices and products

Thermal expansion allowance

The coefficient of linear thermal expansion of TUFFAK sheet is much greater than framing materials, such as aluminum and steel (see table for comparisons). The window design needs to accommodate for adequate expansion room to allow for free movement of the sheet to avoid unsightly sheet bowing and optical distortion. A general guideline is to allow 1/16 inch, (1.52mm) expansion/contraction per foot of sheet in both the length and width directions.

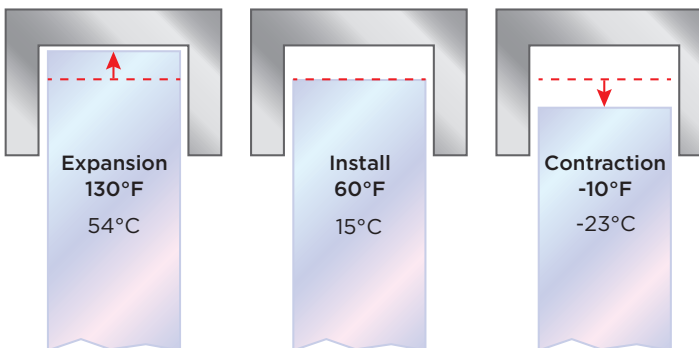

Comparative expansion rates

Material	(Inch/Inch/°F)(cm/cm/ °C)
TUFFAK	0.0000375 (0.000066)
Glass	0.0000050 (0.000009)
Aluminum	0.0000129 (0.000021)
Steel	0.0000063 (0.000011)

Example calculation rabbet depth for a 48-inch, 122cm, sheet length and 70°F, 21°C temperature change

Calculation of Expansion/Contraction

0.0000375 x sheet dimension inches x temperature change
 48" expansion: 0.0000375 x 48 x 70 degrees = 0.13" (3.3mm)
 48" contraction: 0.0000375 x 48 x 70 degrees = 0.13" (3.3mm)
 Rabbet depth:
 Edge engagement + Expansion + Contraction 0.56 + 0.26 = 0.82"(21mm)

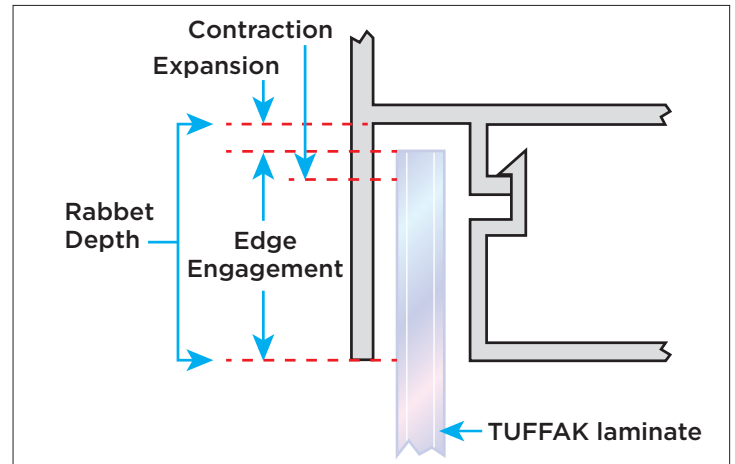

Sheet edge engagement, thermal expansion and rabbet depth table

Sheet size	24"(61cm)	36"(91cm)	48"(122cm)	60"(152cm)
Expansion + Contraction	1/8" (3mm) 1/4" (6mm)	3/16" (4.5mm) 5/16" (7.9mm)		
+ Edge engagement		3/8" (9.5mm) 9/16" (14.3mm)	1/2" (12.7mm) 3/4" (19mm)	
= Rabbet depth		1/2" (12.7mm) 13/16" (20.6mm)	11/16" (17.5mm) 1-1/16" (27mm)	

GLAZING

Wind load

The wind load charts cover a range of sheet sizes and aspect ratios; consult the size closest to the design of interest. Within each chart, the thickness of the sheet is represented in the horizontal axis, and each color line represents a different wind load. The predicted deflection is for a given size window, sheet thickness, and wind load represented in the vertical axis. If a deflection exceeds 2.5 inches (63.5mm), consider thicker sheet for the application.

Wind load deflection calculation assumptions:

- » All edges of the sheet are engaged in the frame
- » Dry glazing with 15% gasket compression clamping force allowing for sliding retention

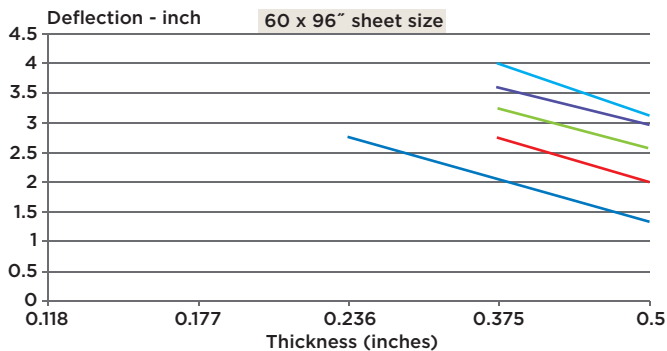
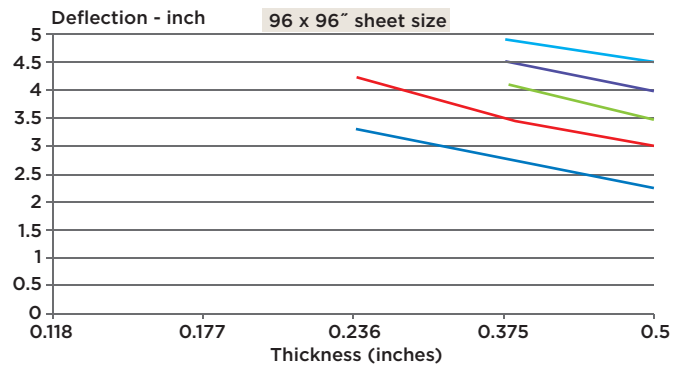
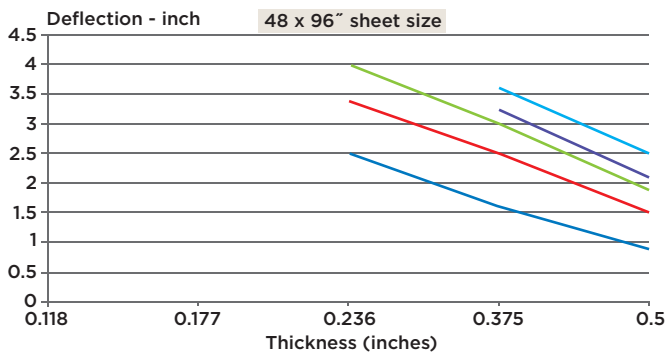
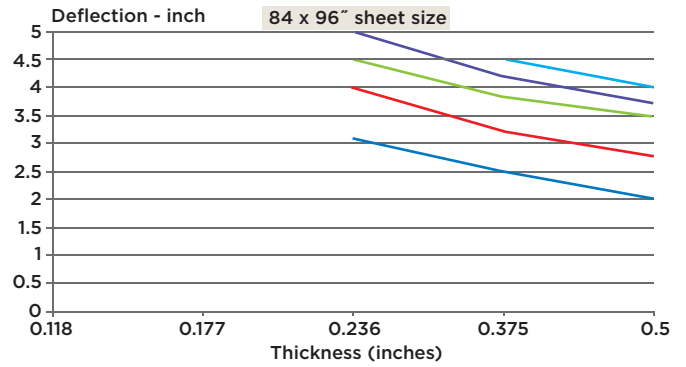
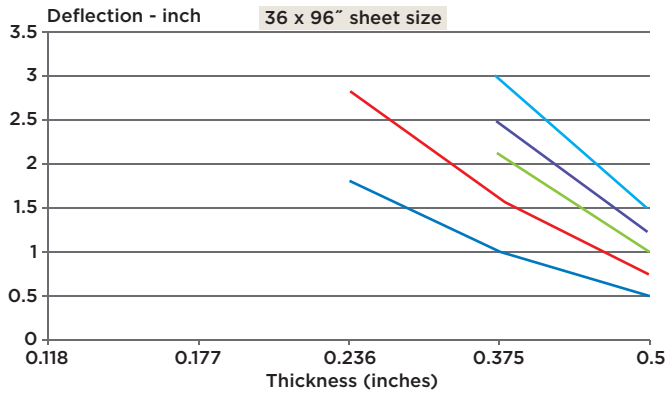
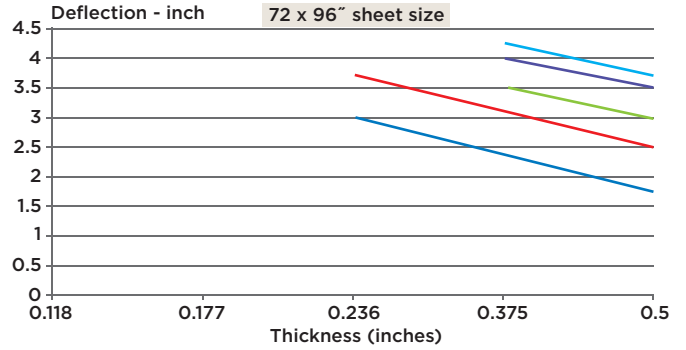
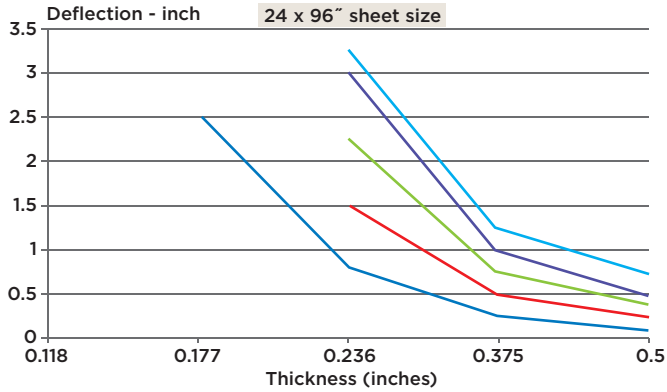

— 10 psf — 20 psf — 30 psf — 40 psf — 50 psf

Design pressure		Hurricane category	MPH /KPH
PSF/kgm ²	MPH/KMPH		
20/98	88/142	1	74-95/119-153
30/146	108/174	2	96-110/154-177
40/195	125/201	3	111-129/178-208
50/244	140/225	4	130-156/209-251
77.5/378	174/280	5	157+/252+

GLAZING

Basic glazing methods

The following requirements apply for both wet and dry glazing:

- » Measure the rabbet depth of the frame
- » Account for design wind load
- » Confirm edge engagement
- » Address potential expansion and contraction of the glazed dimension
- » Check for compatibility and adhesion of gasket, sealant or tape

Wet glazing

Wet-glazing is typically limited up to a 36x36 inch (91cm x 91cm) size window. Glazing shim tape is used to back the sealant cap bead as shown in the image.

Dry glazing

For dry glazing, choose the extruded rubber gasket geometry that will prevent walk out due to sheet thermal movement and deflection. EPDM and neoprene are common gasket products for the interior glazing side of this application. Setting blocks help to allow for drainage via weep holes and also protect the sheet edge from contact with other liquids that might pool in the sill.

Wet/Dry glazing

Wet/dry glazing combination uses an extruded rubber and a sealant product. A soft open cell gasket type that breathes allows curing of the sealant cap bead.

Basic glazing is shown in the illustration. Contact your gasket manufacturer for specific instructions for use, as well as preferred tape and sealant products.

Over-glazing

Over-glazing offers performance enhancements such as energy efficiency and soundproofing. It also offers a design solution where glass alone cannot meet the personal safety requirements or specific threat levels in high risk locations. See more information on soundproofing on page page 66.

Installation considerations

- » Design a large enough air gap between the glass and TUFFAK sheet to accommodate sheet deflection due to wind or attack load.
- » Wind load is not an issue for interior over-glazing, so a thinner sheet may be an option.
- » The framing must be designed to match the performance of the glazing and appropriate to the threat level of the application
- » Clean sash to be certain it is free of manufacturing contaminants such as cutting oil
- » Ensure sash is smooth and free of burrs
- » Confirm size of sash opening and verify a proper design edge engagement, and expansion/contraction allowances
- » Clean and inspect sheet edges for damage after cutting to size
- » Use a glazing gasket, tape or sealant recommended for polycarbonate with an adequate elongation

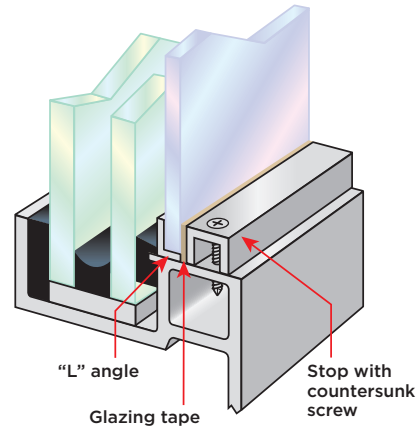
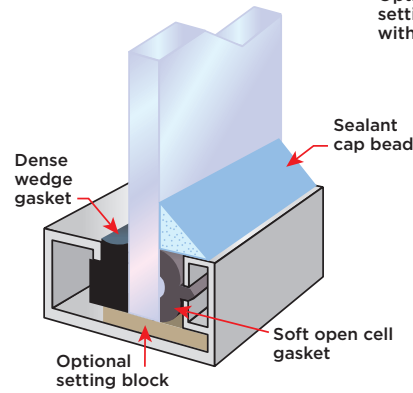
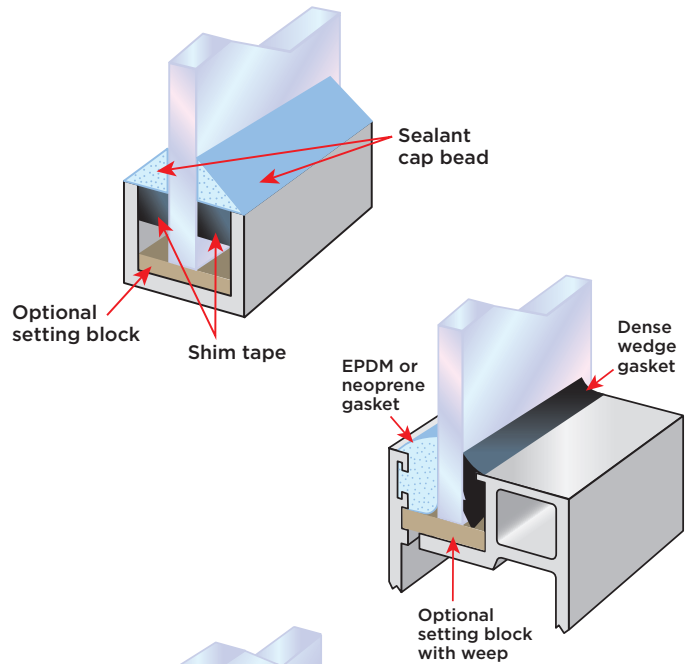

TECH TIP:

To ensure a proper window seal, follow the manufacturer's recommendation for seal compression. As a general rule, 15%-40% impression is adequate for most applications. Over compressing a gasket applies unnecessary stress to the polycarbonate and can lead to product failure. For detailed information visit: www.plaskolite.com

TECH TIP:

IGUs typically consists of two or more sheets separated by a spacer bar to form an air gap. Unfortunately polycarbonate is porous to insulating gases like Xenon, Krypton, or Argon and will not produce a high energy efficiency unit.

GLAZING

Selected gaskets, silicone, tape and framing extrusions

GASKET

Tremco - EPDM/ Neoprene:

<https://www.tremcosealants.com/resources/submittal-builder/glazingfenestration-systems/t3-window-sealing-solutions>

SILICONE

Dow-Corning - 795/995

<http://www.dowcorning.com/applications/search/default.aspx?R=501EN>

Momentive - SCS 2700, SCS1200, SCS 1700, SCS 1800, SCS 2000, SCS 2350, SCS 2800

<http://www.siliconeforbuilding.com>

TAPE

Saint-Gobain - V2100

<https://www.tapesolutions.saint-gobain.com/products/thermalbond-spacer-tape>

Tremco - Polyshim - CRL BLACK 1/8" X 3/8" DOUBLE SIDED FOAM GLAZING TAPE P/N: 98418X38BL

<http://www.tremcosealants.com/products/polyshim-ii-tape.aspx>

Simco International, PE Foam (IXL-Plain Grade) -

KERAFIX FLAXPAN 200 Glazing Tape

3M VHB Tape RP16F, RP25F, RP32F, RP45F, RP62F Carlisle Butyl Tape

FLOWSTRIP: FL 1713 Aluminum Foil Cold Weather Adhesive & FDP 3069L Superior Fabric Protect Tape with Liner

ALUMINUM FRAMING EXTRUSIONS SUPPLY SCOURCES

Eagle Mouldings carries many styles of extruded aluminum channels & aluminum channel extrusions including architectural aluminum channels, C channels, Z channels, U channel, slide track channels, hat channels, nut channels, and aluminum U channels.

<https://eagle-aluminum.com/products/channels/>

GRAINGER

Aluminum U-channel stock is designed with sharp, right-angled inside and outside corners. Also known as an architectural channel, it is lightweight, strong, and resists corrosion.

<https://www.grainger.com/search/raw-materials/aluminum/aluminum-angles-channels>

McMASTER-CARR

Architectural Aluminum H-Channels - More corrosion resistant and easier to form than multipurpose 6061 aluminum, 6063 is primarily used for exterior railings, decorative trim, and door frames.

<https://www.mcmaster.com/aluminum-h-channels/>

FRAMING EXTRUSIONS

Call Technical Service for information 800.628.5084

GLAZING

TUFFAK sheet and HYGARD® laminate products

Thickness (inch)	Light Transmission, Typical %	Shading Coefficient	Solar Heat Gain Coefficient	Total Solar	Solar Absorption %	Solar Reflectance %	U-Factor	
							Summer	Winter
0.118 (3mm)	86	0.99	0.87	83	11	6	0.91	1.00
0.177 (4.5mm)	85	0.99	0.86	82	12	6	0.88	0.96
0.236 (6mm)	84	0.97	0.85	80	14	6	0.85	0.92
0.370 (9.4mm)	80	0.95	0.83	77	17	6	0.78	0.85
0.480 (12.2mm)	77	0.93	0.81	75	16	9	0.73	0.79
Tint	70	0.86	0.75	66	27	7	*	*
Tint	50	0.77	0.67	55	38	7	*	*
Tint	18	0.62	0.54	34	60	6	*	*
BR750	89	0.95	0.83	75	19	6	0.64	0.68
BR1000	66	0.88	0.76	65	30	5	0.56	0.60
BR1250	72	0.91	0.79	68	27	5	0.51	0.54
CG375	82	0.94	0.82	76	18	6	0.77	0.84
CG500	79	0.93	0.81	73	21	6	0.72	0.78
CG750	72	0.90	0.79	69	25	6	0.63	0.68
WG 0.75** (19mm)	71	0.89	0.78	69	23	8	0.62	0.67
WG 1.0** (25.4mm)	64	0.86	0.75	64	29	7	0.56	0.60
WG 1.25** (31.8mm)	59	0.85	0.74	61	32	7	0.50	0.53
WG 2.0** (50.8mm)	48	0.82	0.71	55	39	6	0.39	0.41

*Thickness dependent

**WG products have limited weathering properties, for more information contact your Plaskolite representative or the Sheet Technical Services Group

Noise reduction*

The tables below show sound reduction levels, in decibels, for TUFFAK sheet single and dual glazed systems.

SINGLE GLAZED

TUFFAK thickness (inch)	Rw (dB)	STC (dB)	OITC (dB)
0.118(3mm)	24	24	19
0.177 (4.5mm)	27	27	22
0.236 (6mm)	29	29	24
0.375 (9.52mm)	33	33	27
0.500 (12.7mm)	35	34	30

DUAL GLAZED

Sheet thickness inch/mm	Air Space inch/mm	TUFFAK thickness inch/mm	STC (dB)	OITC (dB)
0.236 PC (6mm)	0.5 (12.7mm)	0.236 (6mm)	28	23
0.250 Glass (6.35mm)	0.5 (12.7mm)	0.5 (12.7mm)	31	26

*STC Sound Transmission Class; Rw Weighted Sound Reduction Index; OITC Outdoor/Indoor transmission Class; ASTM E 90

Solar Transmission / UV Blocking

In terms of energy, sunlight at Earth's surface is around 52 to 55 percent infrared (above 780nm), 42 to 43 percent visible (400 to 780nm), and 3 to 5 percent ultraviolet (below 400nm). Furthermore, the UV region can be separated into three bands: UVA (315-400 nm) UVB (280-315 nm) UVC (100-280 nm). It's UVB which usually does the most damage to plastics and is the type of light energy we need to test when checking plastic's UV resistance. Polycarbonate is not resistant to UV radiation and must be stabilized or protected using UV absorbing additives.

TUFFAK polycarbonate resins are UV stabilized which blocks 100% of UV radiation below 385nm. UV stabilized sheets can further be enhanced with a robust UV absorbing cap layer on one or two sides, that can extend the lifespan of the sheet for many years.

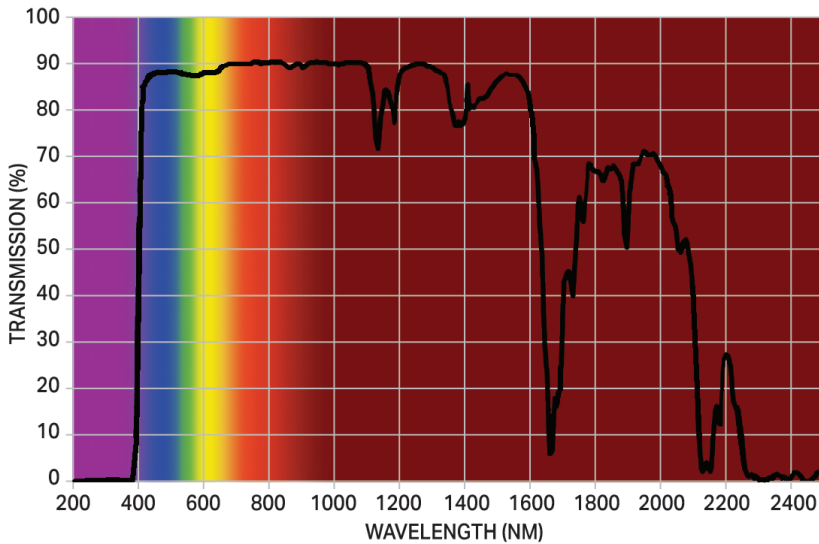

**TUFFAK Sheet:
Light Transmission Curve**

TUFFAK Sign Grade Polycarbonate

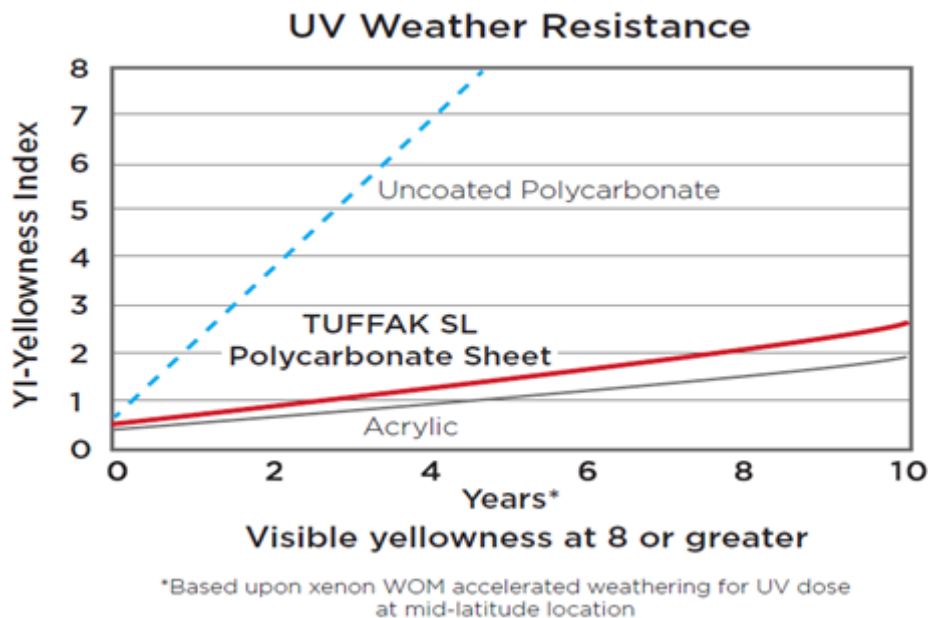

PLASKOLITE

A GLOBAL LEADER IN THE PRODUCTION OF THERMOPLASTIC SHEET

FOUNDED IN 1950

Our Mission: to deliver superior thermoplastic sheet, coatings and polymers to the world, through long-lasting customer relationships and hands-on customer service.

MANUFACTURING LOCATIONS



From our founding, PLASKOLITE strives to treat our employees, our customers, our community and the world, with kindness, dignity and respect. This drives our continuing effort to create sustainable products, in a sustainable manner, for future generations. This on-going commitment is expressed in the

PLASKOLITE Sustainable Ecosystem:

QUICK FACTS

STATUS: Privately held

GLOBAL HEADQUARTERS: Columbus, OH

EMPLOYEES: 1900 Worldwide

MARKETS SERVED: Signage, Lighting, Retail Display, Construction, Transportation, Security, Bath & Spa, Industrial, Architecture, Green Houses

OUR PILLARS OF SUSTAINABILITY

EACH CONTRIBUTES TO MAKING THE WORLD A BETTER PLACE

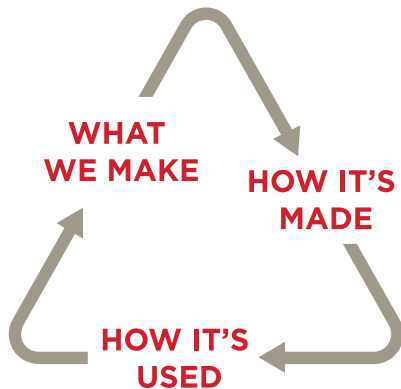

WHAT WE MAKE

Versatile, high-quality, durable thermoplastic materials...not single-use plastics

HOW IT'S MADE

How we make our products reflects our overall philosophy of continuous environmental improvement

HOW IT'S USED

Our thermoplastics play an important role in advancing human well-being, energy conservation and quality of life

These suggestions and data are based on information we believe to be reliable. They are offered in good faith, but without guarantee, as conditions and methods of use are beyond our control. We recommend that the prospective user determines the suitability of our materials and suggestions before adopting them on a commercial scale.

PLASKOLITE

400 W Nationwide Blvd, Suite 400
Columbus, OH 43215
800.848.9124 • Fax: 877.538.0754
plaskolite@plaskolite.com
www.plaskolite.com